

Operator manual

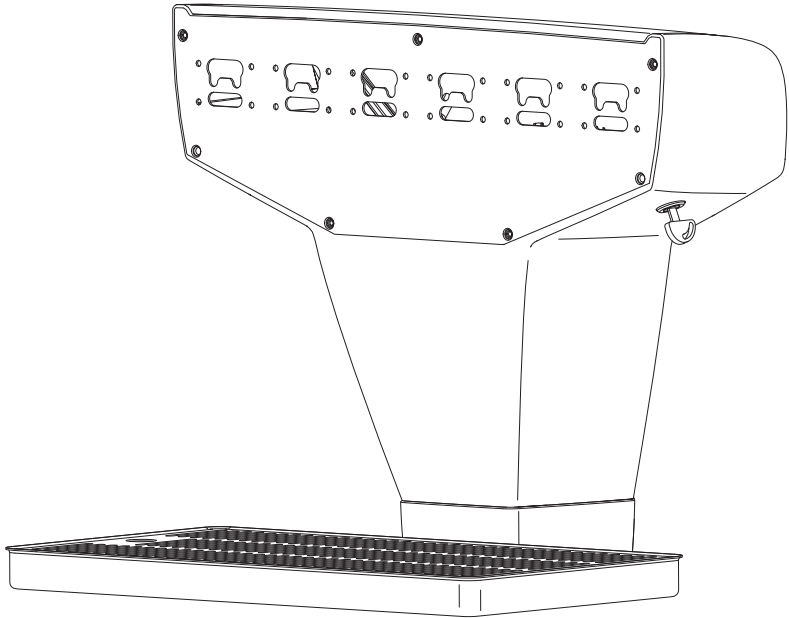

Tower

Nueva Style



Legal notice

Operator manual (Translation of the original manual)

Document no. TD0004000

Tower

Unit ID no. 221000250

Nueva Style

Version

Date of issue: 01/07/2019

Revision status: Index 1

Protection notices (in accordance with DIN ISO 16016:2017-08)

The reproduction, distribution and utilisation of this document as well as the communication of its contents is prohibited, unless expressly permitted. Violations shall result in an obligation to pay damages. All rights reserved with regard to filing for/registering patents, utility models or design patents.

Obligation to preserve records

Please keep this Operator Manual and the Declaration of Conformity in a safe place and transfer them to the subsequent owner/operator if the unit is transferred or sold.

If you lose the Operator Manual or the Declaration of Conformity, you can download them from the website below or request a printed copy from the address below.



NOTICE!

This unit comes with a complete operator manual for the dispensing valves used in the unit. The manual may also be downloaded from the website below or requested as a printed copy from the address below.



Operator manual

Tower

Table of contents

1	Safety	3
1.1	Intended use	3
1.2	Improper use	4
1.3	Staff	5
1.3.1	Operator	5
1.3.2	User	5
1.3.3	Expert	5
1.4	Presentation of warnings	6
1.5	Safety information	7
1.5.1	Disclaimer of liability and warranties	7
1.5.2	Safety information to prevent personal injury and equipment damage	8
2	Handling the Unit Prior to Installation	9
2.1	Unpacking the unit	9
2.2	Storage	10
2.3	Disposal	11
3	Description	12
3.1	Tower	12
3.2	Promotional displays	13
3.3	Dispensing valves	13
3.4	Functions within the dispensing system	14
3.5	Technical data	15
3.5.1	Tower	15
3.5.2	Promotional displays	15
3.5.3	Dispensing valves	16
3.5.4	Connections	17
4	Operation	18
4.1	Preparations for operation	18
4.2	Commissioning	19
4.3	Dispensing beverages	19
4.4	Shutdown	20



5	Maintenance	21
5.1	Maintenance table	21
5.2	Visually inspecting the unit	21
5.3	Cleaning the unit	22
6	Errors and malfunctions	24
6.1	Troubleshooting table	24
7	Applicable documents	26
7.1	Handover certificate	26

1 Safety

1.1 Intended use

By using the unit as intended you will not only protect yourself, but also prevent damage occurring to the unit and its components!

Towers from the Nueva Style series (referred to as “unit” in the following) are intended for use as dispensers of non-alcoholic beverages and their basic ingredients. Food-safe CO₂ is used as conveying medium.

The unit is only suitable for stationary installation in a closed room. Stationary installation is to be carried out by an expert in compliance with all of the specifications given in this document; see the document “Tower installation and service manual”, document no. TD0004100.

The unit may only be operated in locations and ambient conditions which meet all of the requirements of an installation location; see the document “Tower installation and service manual”, document no. TD0004100.

In particular, intended use means that you will carry out all activities with and on the unit to the specifications provided in this document.

This unit is only to be operated by those who meet the requirements set out in this document; see chapter 1.3.2.

Work on the unit and its components not included in the activities described in this document may only be performed by experts; see chapter 1.3.3.

1.2 Improper use

Improper use of the unit, and unauthorised modifications to the unit and its components may cause personal injury and equipment damage for which Cornelius Deutschland GmbH shall assume no liability. Improper use of the unit is prohibited.

The following in particular is regarded as improper use:

- Mobile operation of unit.
- Use by persons (including children) with physical, sensory or mental disabilities or those with insufficient experience and knowledge, unless they are supervised by a person responsible for their safety, or this person has instructed them in the use of the unit.
- Use, operation and maintenance by children under 8 years.
- Children are not to play with the unit. Cleaning and maintenance work must not be carried out by children unattended.
- Use by those under the influence of medication, alcohol, drugs or other substances which impair their physical, sensory or mental abilities.
- Operating the unit below the minimum and above the maximum ambient temperature (for minimum and maximum temperatures, see chapter 3.5).
- Operating the unit with conveying media other than those defined in this document; see chapter 1.1.
- Operating the unit in locations and ambient conditions which do not fully meet the requirements of the installation and service manual; see the document “Tower installation and service manual”, document no. TD0004100.
- Operation of the unit by untrained staff.
- Carrying out cleaning and other types of maintenance work on the unit which contradict this document or are not included in it.

1.3 Staff

1.3.1 Operator

The operator is the natural or legal person who uses the unit or on whose behalf the unit is used. The operator must ensure that the unit is only used as intended, in observance of the safety instructions set out in this document.

The operator must ensure that all users read and understand the safety information. The operator is responsible for the planning and proper implementation of regular safety inspections and maintenance work.

With regard to operating the unit, Cornelius Deutschland GmbH recommends observing the national regulations of the country of use which govern the operation of beverage-dispensing systems.

1.3.2 User

The operator specifies who will operate this unit. Cornelius recommends the following:

- If this unit is only to be operated by employees, they are to be instructed in its use, demonstrate their abilities to use it to the operator or their authorised representative, and be expressly charged with its use. This document is to be available to staff at all times.
- If this unit is openly accessible and set up so that untrained staff can use it, the operator is to provide instructions for use directly at the unit; these must be clearly understood by this group of people, therefore ensuring that the unit will be handled safely.

1.3.3 Expert

An expert in terms of this document refers to someone who has the relevant training, experience and information and knowledge of relevant standards, laws, regulations, accident prevention regulations, generally accepted safety-related regulations and operating conditions to be able to perform the required activities as well as recognise potential risks and avert them. For assignments requiring expert knowledge, e.g. in electrical engineering, mechanics or fluid technology, only skilled workers with the right qualifications are to carry these out.

An expert must also have received technical training in the unit-specific special features of Cornelius products. The assigned tasks are always to be carried out in compliance with the relevant installation and service manual for the unit concerned; see the document "Tower installation and service manual", document no. TD0004100.

1.4 Presentation of warnings

The classification of warnings is based on ISO 3864-2 and ANSI Z535.6, using the key terms of¹

- “Danger”, “Warning” and “Caution” in the case of personal injury,
- “Attention” in the case of equipment damage and
- “Notice” to impart general information.

This document classifies and presents the various pieces of safety information as follows:



DANGER!

marks a danger with a **high risk**², which will result in serious injury or death if not avoided.



WARNING!

marks a danger with a **medium risk**², which may result in serious injury or death if not avoided.



CAUTION!

marks a danger with a **low risk**², which may result in minor to moderate injury if not avoided.



ATTENTION!

marks a potentially damaging situation in which the product or objects may be damaged if not avoided.



NOTICE!

marks tips for use and other particularly useful information that may not be recognised at first glance.



SAFETY INFORMATION!

marks safety information which must be observed in the stated operating situation.

¹ Not all of the following key terms need to be used in this documentation.

² Risk = extent x likelihood of occurrence

1.5 Safety information

Any work on the unit and its components which goes beyond the operation and servicing and maintenance that the operator is authorised for, may only be performed by **experts** (for a definition of experts, see chapter 1.3.3). Furthermore, it is crucial that when performing work on the unit all safety information is observed; this information is set out in the following sections. Some of the tasks may have additional safety information which highlights the specific dangers or hazards associated with such work.

1.5.1 Disclaimer of liability and warranties

If work is undertaken on the unit which is not described in this document, Cornelius Deutschland GmbH shall not assume any liability for any resulting hazards and damages. The same applies to described work which is partly or not fully performed in compliance with the regulations set out in this document.



WARNING!

Risk of personal injury and equipment damage due to improperly executed work!

Improperly executed work at the unit will cause dangers to persons and damage to the unit.

- Have all work at the unit carried out by Cornelius Deutschland GmbH or by a service partner.
-



WARNING!

Risk of personal injury and equipment damage due to the use of non-approved spare parts and accessories!

Using spare parts and accessories that are not recommended by the manufacturer may lead to personal injury and equipment damage.

- For your own safety and to protect your warranty, only use original spare parts.
-

1.5.2 Safety information to prevent personal injury and equipment damage

Please always observe the following safety information in order to prevent personal injury occurring:



DANGER!

Risk of death from electric shock!

Touching live electrical parts will result in a risk of electric shock!

- Do not carry out any work on the electrical system.
-



WARNING!

Risk of burns when touching hot parts of the unit!

Touching parts of the unit after it has been in continuous use over an extended period of time will result in a risk of burns.

- Take appropriate safeguard measures, such as by wearing heat-resistant protective gloves.
-



WARNING!

Risk of personal injury and equipment damage due to improper operation!

Risk of death from improper operation!

- Make sure that only users who are users as defined in the user section use the unit; see chapter 1.3.2.
 - Children must be supervised to ensure that they do not play at or with the unit.
-



NOTICE!

In particular, safety standards are to be observed in their scope of validity (e.g. EN 60335-2-75).

2 Handling the Unit Prior to Installation

2.1 Unpacking the unit

**NOTICE!**

Cornelius Deutschland GmbH is not responsible for damaged deliveries. If any damage is found, all packaging material is to be kept and the freight carrier is to be contacted. If the freight carrier is not contacted within 48 hours of receipt of delivery, the warranty claim might be rendered void.

**NOTICE!**

The unit is thoroughly checked ex works before being shipped. The freight carrier has confirmed and acknowledged receipt. All damage or irregularities are to be noted at the time of delivery and reported immediately to the freight carrier delivering. Please request a written inspection report from the claims inspector to substantiate any claim.

1. Inspect the cardboard box and make a note of any damage however minimal this may seem. If the cardboard box is damaged, please make a note of the following on the copy of your freight invoice: "exterior cardboard box damage – concealed damage possible". Please contact the freight company immediately.
2. Open the cardboard box, packaging material and plastic bag in which the unit is packed. Check the unit thoroughly for damage and to make sure it is complete in accordance with table 2-1.
3. Remove the packaging material from the top of the unit.
4. Check the unit housing and make sure that there are no scratches, dents or other superficial defects.
5. Make sure that the glass or plastic has no scratches or cracks.
6. Open the package with the loose individual parts and check all parts for damage and completeness. Check that the received parts correspond with the packing list and make sure that you have received all parts.

**NOTICE!**

Do not put the unit down on its front or sides without the packaging as this may damage the unit. This will render the warranty claim void.

No.	Description	Qty/amount
1	Tower	1
2	Drip tray & grill	1
3	Operator manual	1
4	Installation and service manual or information sheet on installation and service manual	1
5	Fastening materials	1

Tab. 2-1 Cardboard box content

2.2 Storage

Avoid excessive temperature fluctuations as condensate may form, which in turn may cause damage to the unit or to the components.

The permissible storage temperature is $-10\text{ }^{\circ}\text{C}$ to $+50\text{ }^{\circ}\text{C}$.

The acclimatisation period is 6 hours.



ATTENTION!

Damage due to improper storage!

Dirt or moisture entering a unit, as well as certain weather conditions (e.g. condensate forming in the unit, sunlight) will cause damage to the unit and its components.

- Protect the unit and its components by storing the unit in a clean and dry place, and by ensuring stable ambient conditions.
- If possible, store the unit in its original packaging. Unpacked units must be covered with a dustproof cover. No condensate must form under the cover.



ATTENTION!

Risk of electrostatic charge!

Improper handling or storage may result in electrostatic charges.

- If possible, store units and/or any electronic components in their original packaging.
- Keep units and/or electronic components away from charged objects, fields and insulators.
- Avoid electrostatic charges when removing packaging and/or handling electronic assemblies and components by working at an ESD-protected workstation or work area.
- When working at the unit or its components, wear a grounding (anti-static) wrist strap at the very least and wear antistatic gloves if necessary.

**ATTENTION!****Component damage due to material ageing!**

Material can age due to long storage periods, thereby affecting the material's properties (e.g. plastics and seals may become brittle). The properties of lubricants may change due to long storage periods.

- Check the assemblies and components for damage before each use/ before installing them. Do not install assemblies or components that show visible signs of ageing.
-

**ATTENTION!****Component damage due to freezing liquids!**

Ambient temperatures that are below freezing will lead to the freezing of any water or cleaning agent residue remaining inside the unit. This will lead to damage to internal components.

- Before shipment, storage or relocation of the unit, the unit is to be cleaned and the cleaning solution is to be fully drained from the unit.
-

2.3 Disposal

Disposal of the units must be carried out in compliance with the applicable local and/or national and international regulations. Units must not be disposed of with household waste.

If the unit contains fuels or lubricants in liquid, paste-like or gaseous form, such as oil, grease, cooling agents etc., such fuels or lubricants are to be collected using appropriate measures and disposed of in compliance with the applicable local and/or national and international regulations. Such fuels or lubricants must always be prevented from seeping into the ground, the sewage system and any bodies of water, and must always be prevented from entering the atmosphere.

3 Description

3.1 Tower

The unit comprises the following assemblies:

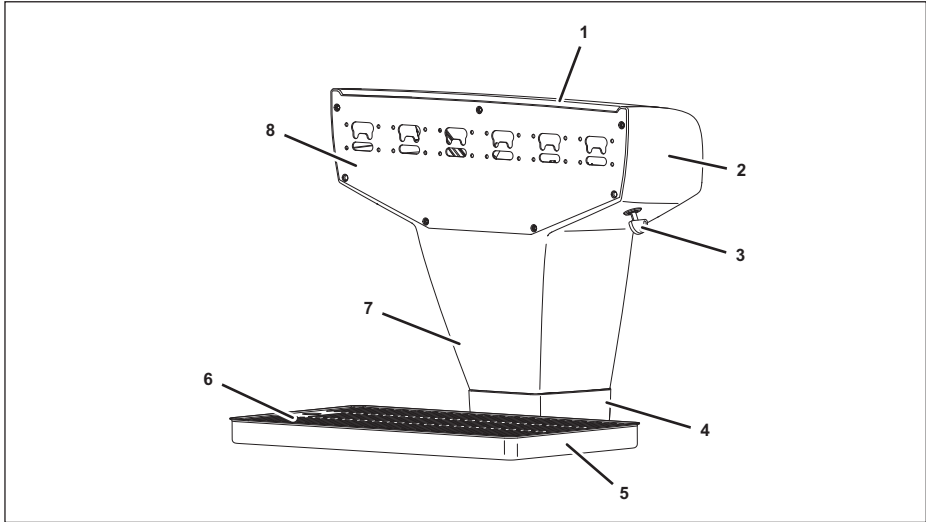

Fig. 1

- | | |
|-----------------|----------------------------|
| 1 Hood | 5 Drip tray |
| 2 Front panel | 6 Grill |
| 3 Key switch | 7 Rear panel |
| 4 Stand booster | 8 Dispensing valve support |

3.2 Promotional displays

The unit allows a range of promotional displays to be selected. Upon delivery, any promotional displays will already be pre-installed on the unit or will be installed on site by a service partner. In case of a defective promotional display, please contact your service partner.

Fig. 2: Taxi cab hood with promotional sign

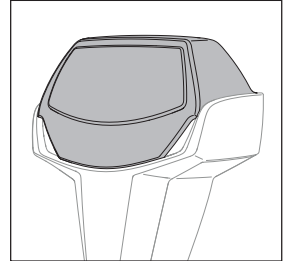

Fig. 2

Fig. 3: Taxi cab hood with display

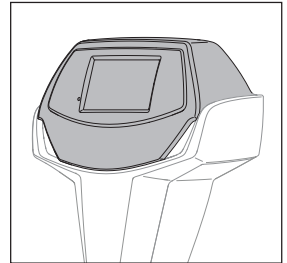

Fig. 3

Fig. 4: Hood with sandblasted logo

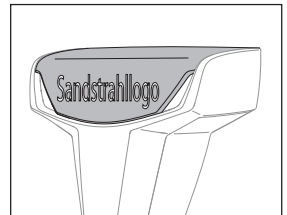

Fig. 4

3.3 Dispensing valves



NOTICE!

Information on the dispensing valves installed on your unit can be found in the binding documentation for the respective dispensing valve.

3.4 Functions within the dispensing system

The unit controls the dispensing of chilled, non-alcoholic beverages. The beverages are supplied via a suitable undercounter cooler with a CO₂ conveying medium, and the python which acts as the connecting part between the undercounter cooler and the unit; see Fig. 5.

The following can be dispensed:

- Still water
- Carbonated water (soda)
- Up to eight postmix beverages

The system is operated via the installed dispensing valves. The beverage is dispensed via the dispensing valves into a cup previously placed under the dispensing valve by the user. The dispensed quantity can either be preset or manually controlled (depending on the configuration); see dispensing valve documentation.

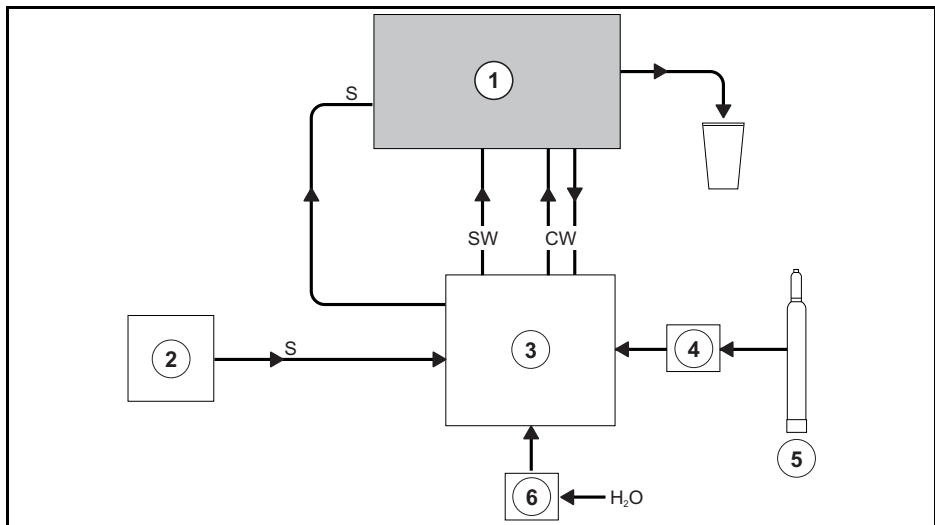

Fig. 5

- | | |
|-----------------------|---------------------------|
| 1 Tower | 4 Pressure-reducing valve |
| 2 Syrup/BIB | 5 CO ₂ |
| 3 Undercounter cooler | 6 Water filter (optional) |

S = syrup
SW = still water

CW = carbonated water
H₂O = tap water

3.5 Technical data

3.5.1 Tower

Description	Parameter	Value	Unit
Dimensions	Height	325 – 470 (12.8 – 18.5)	mm (inches)
	Width	420 – 552 (16.5 – 21.7)	mm (inches)
	Depth incl. drip tray	365 (14.4)	mm (inches)
Ambient temperature	Storage	-10 to +50	°C
	Operating environment	+10 to +32	°C
Power supply	Supply voltage	24	V AC
	Frequency	50 – 60	Hz
Power input ¹	max.	100	W
Current consumption ¹	max.	4	A
Python length ²	max.	50	m
Postmix	Depending on unit type	5 – 8	pcs.
Still water	Depending on unit type	1 – 4	pcs.
Key switch		I/O	
Sound emission		< 65	dB (A)

1. Dispensing to four dispensing valves simultaneously

2. Depending on the refrigerating unit

3.5.2 Promotional displays

Taxi cab hood with promotional sign

Description	Parameter	Value	Unit
Taxi cab hood	Height	225 (8.9)	mm (inches)
	Width	395 (15.6)	mm (inches)
	Depth	164 (6.5)	mm (inches)
Front promotional sign	Height	152 (6.0)	mm (inches)
	Width	342 (13.5)	mm (inches)
	Depth	20 (0.8)	mm (inches)
Rear promotional sign	Height	83 (3.3)	mm (inches)
	Width	346 (13.6)	mm (inches)
	Depth	6 (0.2)	mm (inches)

Taxi cab hood with display

Description	Parameter	Value	Unit
Taxi cab hood	Height	225 (8.9)	mm (inches)
	Width	395 (15.6)	mm (inches)
	Depth	164 (6.5)	mm (inches)
Display	Height	109 (4.3)	mm (inches)
	Width	192 (7.6)	mm (inches)
	Depth	25 (1.0)	mm (inches)
Rear promotional sign	Height	83 (3.3)	mm (inches)
	Width	346 (13.6)	mm (inches)
	Depth	6 (0.2)	mm (inches)

Hood with sandblasted logo

Description	Parameter	Value	Unit
Dimension of hood	Height	131 (5.2)	mm (inches)
	Width	393 (15.5)	mm (inches)
	Depth	163 (6.4)	mm (inches)
Dimension of sand-blasted logo	max. height	60 (2.4)	mm (inches)
	max. width	200 (7.9)	mm (inches)

3.5.3 Dispensing valves

NOTICE!

Information on the dispensing valves installed on your unit can be found in the binding documentation for the respective dispensing valve.

3.5.4 Connections

Postmix

Connection	Type/connection assignment		
	with soda dispenser	without soda dispenser	
Carbonated water inlet	3/8 inch ID ¹ , 1/2 inch OD ²	10 mm ID, 15 mm OD	3/8 inch ID, 1/2 inch OD
Carbonated water return	3/8 inch ID, 1/2 inch OD	10 mm ID, 15 mm OD	3/8 inch ID, 1/2 inch OD
Still water inlet	1/4 inch ID, 3/8 inch OD	6 mm ID, 9.5 mm OD	1/4 inch ID, 3/8 inch OD
Postmix inlets	1/4 inch ID, 3/8 inch OD	6 mm ID, 9.5 mm OD	1/4 inch ID, 3/8 inch OD

1. ID = inside diameter

2. OD = outside diameter

4 Operation



NOTICE!

The unit is set up and commissioned by the service partner. Once complete, you will receive initial instruction on how to operate and maintain the unit. The following describes the operating sequences and will help familiarise you with how the unit works.



DANGER!

Risk of personal injury and equipment damage due to non-compliance with safety information!

Failure to observe the safety information will result in a risk of bringing about operating conditions at the unit, which may cause personal injury or equipment damage.

- Please always strictly observe all safety measures and information/instructions; see chapter 1.
-

The unit is operated via the individual dispensing valves; see dispensing valve documentation.

4.1 Preparations for operation

1. Check the beverage connection and beverage reserves; see the document "Undercounter cooler operator manual".
2. Check that the undercounter cooler is fully operational; see the document "Undercounter cooler operator manual".
3. If required, modify the unit configuration as needed; see dispensing valve documentation.

4.2 Commissioning



NOTICE!

The following describes how the operator or user can put the unit back into service following temporary shutdown (< 24 hours).

If the unit has to be put back into service after a long shutdown (> 24 hours), this may only be carried out by an expert, see chapter 1.3.3, as the unit has to be cleaned.

1. Clean the unit, assemblies, and components; see chapter 5.3.
2. Turn the key switch (Fig. 6/1) to position "I".

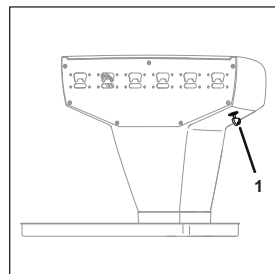

Fig. 6

4.3 Dispensing beverages



NOTICE!

Information on the beverage dispensing mechanism can be found in the binding documentation for the respective dispensing valve.

4.4 Shutdown



NOTICE!

The following describes how the operator or user can temporarily shut down the unit (< 24 hours).

If the unit has to be shut down for a longer period (> 24 hours), this may only be carried out by an expert, see chapter 1.3.3, as the unit has to be cleaned and drained.

1. Turn the key switch (Fig. 7/1) to position "0".
2. Clean the unit, assemblies, and components; see chapter 5.3.

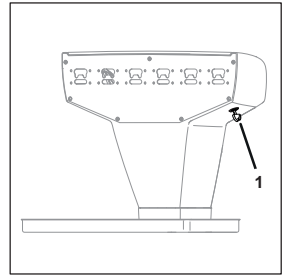

Fig. 7

5 Maintenance



DANGER!

Risk of personal injury and equipment damage due to non-compliance with safety information!

Failure to observe the safety information will result in a risk of bringing about operating conditions at the unit, which may cause personal injury or equipment damage.

- Please always strictly observe all safety measures and information/instructions; see chapter 1.

5.1 Maintenance table



NOTICE!

The following table provides information on recommended maintenance intervals to be adapted to the relevant installation situation.

Interval	Components	Action
Daily	Tower, outside	Perform a visual inspection; see chapter 5.2
Daily	Tower, outside	Clean; see chapter 5.3
Every 3 months	Tower, inside	Clean tubes/valves Please contact your service partner

5.2 Visually inspecting the unit

1. Inspect the unit for damage.
Always replace any damaged components and parts.
Please contact your service partner.
2. Perform a visual inspection of the dispensing valves; see dispensing valve documentation.
3. Check that the drip tray (Fig. 8/1) is positioned properly on the unit.
4. Inspect the unit for leakages.
If there are any leaks, please inform your service partner.
5. Check the legibility of the warning signs.
Always replace any illegible warning signs. Please contact your service partner.

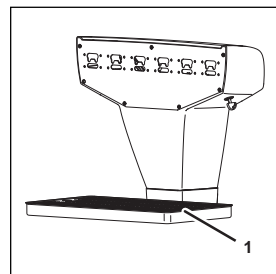

Fig. 8

5.3 Cleaning the unit

Required tools/materials	ID/reference	Qty/amount	Comment
Approved cleaning agent		1	
Non-abrasive cloth		1	
Paper towel		1	



ATTENTION!

Material damage!

Improper cleaning leads to damage on the unit and material.

- Do not use a rough scouring agent.
- Do not use a solvent containing oil.
- Never put individual parts in the dishwasher.
- Never clean the unit with a water jet.

1. Clean the dispensing valves; see dispensing valve documentation.
2. Remove the grill from the drip tray.

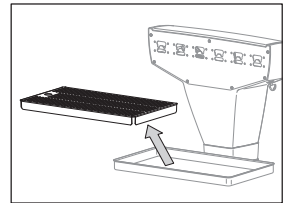

Fig. 9

3. Remove the drip tray from the unit.
4. Clean the area underneath the drip tray.

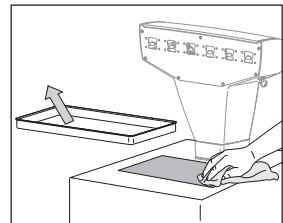

Fig. 10

5. Clean the grill with a clean, damp cloth and, if necessary, an approved cleaning agent.
6. Dry the grill with a paper towel.

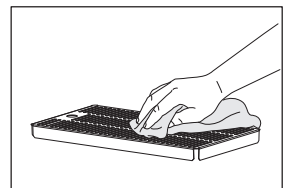

Fig. 11

7. Clean the drip tray with a clean, damp cloth and, if necessary, an approved cleaning agent.
8. Dry the drip tray with a paper towel.

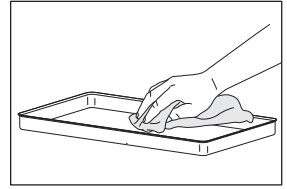

Fig. 12

9. Position the drip tray on the unit.
10. Insert the grill in the drip tray.

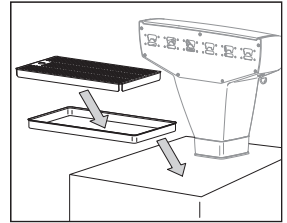

Fig. 13

11. Clean the unit with a clean, damp cloth and, if necessary, with an approved cleaning agent.
12. Dry the unit with a paper towel.

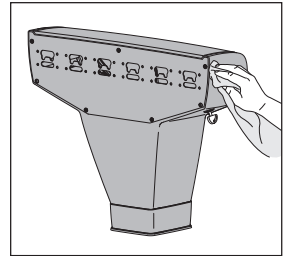

Fig. 14

6 Errors and malfunctions



NOTICE!

All installation, maintenance and repair work at the unit is to be carried out by an expert only.

6.1 Troubleshooting table

Fault	Probable cause	Remedy
Unable to dispense	No mains/power supply connected	Please contact your service partner
	Tower is not switched on	Turn the key switch to position "I"; (see chapter 4.2)
	Fault or error on the dispensing valve	Please contact your service partner
	Fault or error on the undercounter cooler	See undercounter cooler documentation
Beverage is too warm	Fault or error on the undercounter cooler	See undercounter cooler documentation
Beverage foams for all products	Soda water is too warm	Please contact your service partner
	CO ₂ feed pressure for the soda circuit is too high on the relevant pressure-reducing valve	Adjust the CO ₂ feed pressure to the required value (see documentation on the CO ₂ system)
	Syrup has been stored too long and has had CO ₂ added	Connect a new syrup container (see undercounter cooler documentation)
	Contaminated tubes	Please contact your service partner

Fault	Probable cause	Remedy
Only soda is being dispensed	Syrup container is empty	Connect a new syrup container (see undercounter cooler documentation)
	Connections on the syrup container are not properly connected	Connect the connections on the syrup container properly (see documentation on the syrup container)
	CO ₂ feed pressure for the syrup tube is set incorrectly on the relevant pressure-reducing valve	Adjust the CO ₂ feed pressure to the required value (see documentation on the CO ₂ system)
	Syrup tube is contaminated	Please contact your service partner
	Fault or error on the undercounter cooler	See undercounter cooler documentation
Only syrup is being dispensed	Shut-off valve or pressure-reducing valve for the fresh water supply is closed	Open the shut-off valve and pressure-reducing valve for the fresh water supply (see documentation on the drinking water system)
	Fault or error on the undercounter cooler	See undercounter cooler documentation
	Fault or error on the dispensing valve	See dispensing valve documentation
Soda/syrup ratio is incorrect	Fault or error on the dispensing valve	See dispensing valve documentation
	CO ₂ feed pressure for the syrup tube is set incorrectly on the relevant pressure-reducing valve	Adjust the CO ₂ feed pressure to the required value (see documentation on the CO ₂ system)
Insufficient amount of CO ₂ in the beverage	CO ₂ pressure for soda is set incorrectly on the relevant pressure-reducing valve	Correctly adjust the CO ₂ pressure for soda on the relevant pressure-reducing valve (see documentation on the CO ₂ system)
	Fault or error on the undercounter cooler	See undercounter cooler documentation
	CO ₂ supply too low	Change the CO ₂ bottle

7 Applicable documents

7.1 Handover certificate

1. Name of the place of operation

(Name of the place of operation)

(Street address, house no.)

(Postcode, town)

(Name of the operator)

2. Operator copy

The operator has been instructed in the use of the unit.

The unit has been handed over to the operator in good working order and in a condition that is clean and safe to operate.

Date

Stamp and signature
Operator

Stamp and signature
Installer of the unit

3. Installer copy

The operator has been instructed in the use of the unit.

The unit has been handed over to the operator in good working order and in a condition that is clean and safe to operate.

Date

Stamp and signature
Operator

Stamp and signature
Installer of the unit

4. Evidence of instruction

I hereby confirm that on _____ (date) I was instructed
on the following topics:

- General sequence of operations
- Reference to existing documentation
- Cleaning the unit

Last name/first name

Signature

Last name/first name

Signature

Last name/first name

Signature

Last name/first name

Signature

Last name/first name

Signature

Last name/first name

Signature

Last name/first name

Signature

Last name/first name

Signature

Last name/first name

Signature

Last name/first name

Signature



www.cornelius-emea.com

Cornelius Deutschland GmbH
Carl-Leverkus-Str. 15
40764 Langenfeld
Germany

Tel.: +49 (0) 21 73 / 79 3 – 0
Fax: +49 (0) 21 73 / 77 4 – 38
E-Mail: info@cornelius.com