

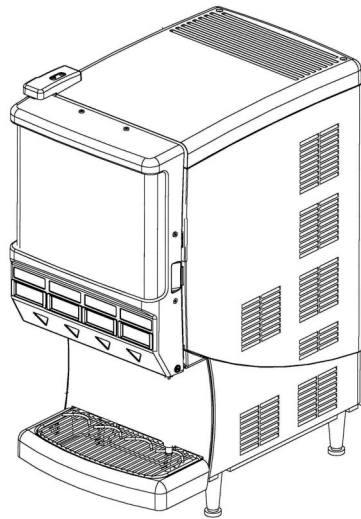

QUEST ELITE 4290

Installation, Service and Decommissioning Manual



QUEST ELITE 4000

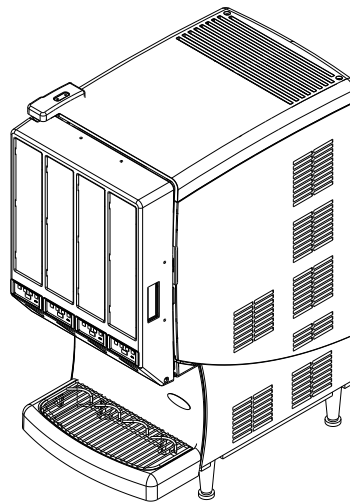

QUEST ELITE 4000 (VERTICAL)

Release Date: September 2, 2022

Publication Number: 721Q45112MNL

Revision Date: September 2, 2022

Revision: A

Visit the Cornelius web site at www.cornelius.com for all your Literature needs.

The products, technical information, and instructions contained in this manual are subject to change without notice. These instructions are not intended to cover all details or variations of the equipment, nor to provide for every possible contingency in the installation, operation or maintenance of this equipment. This manual assumes that the person(s) working on the equipment have been trained and are skilled in working with electrical, plumbing, pneumatic, and mechanical equipment. It is assumed that appropriate safety precautions are taken and that all local safety and construction requirements are being met, in addition to the information contained in this manual.

This Product is warranted only as provided in Cornelius' Commercial Warrant applicable to this Product and is subject to all of the restrictions and limitations contained in the Commercial Warranty.

Cornelius will not be responsible for any repair, replacement or other service required by or loss or damage resulting from any of the following occurrences, including but not limited to, (1) other than normal and proper use and normal service conditions with respect to the Product, (2) improper voltage, (3) inadequate wiring, (4) abuse, (5) accident, (6) alteration, (7) misuse, (8) neglect, (9) unauthorized repair or the failure to utilize suitably qualified and trained persons to perform service and/or repair of the Product, (10) improper cleaning, (11) failure to follow installation, operating, cleaning or maintenance instructions, (12) use of "non-authorized" parts (i.e., parts that are not 100% compatible with the Product) which use voids the entire warranty, (13) Product parts in contact with water or the product dispensed which are adversely impacted by changes in liquid scale or chemical composition.

Contact Information:

To inquire about current revisions of this and other documentation or for assistance with any Cornelius product contact:

www.cornelius.com

800-238-3600

Trademarks and Copyrights:

This document contains proprietary information and it may not be reproduced in any way without permission from Cornelius.

This document contains the original instructions for the unit described.

MARMON FOOD SERVICE TECHNOLOGIES

355 KEHOE BLVD

CAROLSTREAM IL

TEL:+1-800238-3600

Printed in U.S.A.

TABLE OF CONTENTS

INSTALLATION

SAFETY INSTRUCTIONS	1
Read And Follow All Safety Instructions	1
Safety Overview	1
Recognition	1
Different Types of Alerts	1
Safety Tips	1
Qualified Service Personnel	2
Safety Precautions	2
Shipping And Storage	2
Mounting In or On A Counter	2
R290 Refrigerant Warnings	3
UNIT DIMENSIONS	5
Receiving	6
Unpacking	6
Nameplate Data	6
Concentrate Storage	6
Ice Bank/Pull Down	6
Applications	6
INSTALLATION REQUIREMENTS	7
Counter Location	7
Minimum Airflow Clearance	7
Connecting the Water Supply	7
Plumbing and Water Supply Requirements	8
FILLING THE ICE BATH	9
Electrical Requirements	10
PRIMING/FLUSHING WATER SYSTEM	10
CONCENTRATE HANDLING AND LOADING	11
Loading Concentrate	11
Changing Concentrate Containers	11
BRIXING PROCEDURE	13
Supplies	13
Checking/Adjusting the BRIX Setting	13
Programming the Portion Control	14
Stop Button	14
PLANNED MAINTENANCE SCHEDULE	15
Daily	15
Flush System	15
Clean Splash Zones & Dispense Nozzles	15
Weekly	15
Sanitize the Juice Dispenser	16
Sanitize Pump System	16
Prepare Dispenser for Use	17
Semi Annually	17
Clean Water Inlet Strainer	17

Clean Chassis Interior	17
Check and Top-Off Water Ice Bath	18
Annually	18
Replace Pump Tubing and Clean Cabinet	18
Removing Pump Platform(s)	18
Replacing the Tubing	19
Cleaning the Cabinet	20
ASSEMBLY DRAWINGS	20

TABLE OF CONTENTS

SERVICE PROCEDURES

SAFETY INSTRUCTIONS	21
Read and Follow ALL Safety Instructions	
Safety Overview	
Recognition	
Different Types of Alerts	
Safety Tips	
Qualified Service Personnel	
Safety Precautions	
Refrigeration Servicing	
Shipping And Storage	
Mounting in or on a Counter	
Specialized Precautions and Guidelines for Servicing Units Using R290 Refrigerant	26
UNIT SPECIFICATIONS	27
CONCENTRATE HANDLING AND LOADING	28
BRIXING PROCEDURE	30
Supplies	30
Checking/Adjusting the BRIX Setting	30
PLANNED MAINTENANCE SCHEDULE	32
Daily	32
Flush System	32
Clean Splash Zones & Dispense Nozzles	33
Weekly	33
Sanitize the Juice Dispenser	33
Sanitize Pump System	33
Prepare Dispenser for Use	34
Semi Annually	35
Clean Water Inlet Strainer	35
Clean Chassis Interior	35
Check and Top-Off Water Ice Bath	36
Annually	36
Replace Pump Tubing and Clean Cabinet	36
Removing Pump Platform(s)	36

Replacing the Tubing	37
Cleaning the Cabinet	39
Assembly Drawings	40
Dispenser Motor Speeds Selection (DIP Switches)	44
TROUBLESHOOTING GUIDE	45
Cornelius Standard Service Call Guide	48

TABLE OF CONTENTS

DECOMMISSIONING

DECOMMISSIONING PROCESS	49
-------------------------------	----

SAFETY INSTRUCTIONS

READ AND FOLLOW ALL SAFETY INSTRUCTIONS

Safety Overview

- Read and follow **ALL SAFETY INSTRUCTIONS** in this manual and any warning/caution labels on the unit (decals, labels or laminated cards).
- Read and understand ALL applicable OSHA (Occupational Safety and Health Administration) safety regulations before operating this unit.

Recognition

<i>Recognize Safety Alerts</i>
 <p><i>This is the safety alert symbol. When you see it in this manual or on the unit, be alert to the potential of personal injury or damage to the unit.</i></p>

Different Types of Alerts

DANGER:

Indicates an immediate hazardous situation which if not avoided **WILL** result in serious injury, death or equipment damage.

WARNING:

Indicates a potentially hazardous situation which, if not avoided, **COULD** result in serious injury, death, or equipment damage.

CAUTION:

Indicates a potentially hazardous situation which, if not avoided, **MAY** result in minor or moderate injury or equipment damage.

SAFETY TIPS

- Carefully read and follow all safety messages in this manual and safety signs on the unit.
- Keep safety signs in good condition and replace missing or damaged items.
- Learn how to operate the unit and how to use the controls properly.
- **Do not** let anyone operate the unit without proper training. This appliance is **not** intended for use by very young children or infirm persons without supervision. Young children should be supervised to ensure that they do not play with the appliance.
- Keep your unit in proper working condition and do not allow unauthorized modifications to the unit.

NOTE: The dispenser is not designed for a wash-down environment and MUST NOT be placed in an area where a water jet could be used.

QUALIFIED SERVICE PERSONNEL

WARNING:

Only trained and certified electrical, plumbing and refrigeration technicians should service this unit.

ALL WIRING AND PLUMBING MUST CONFORM TO NATIONAL AND LOCAL CODES. FAILURE TO COMPLY COULD RESULT IN SERIOUS INJURY, DEATH OR EQUIPMENT DAMAGE.

IF THE SUPPLY CORD IS DAMAGED, IT MUST BE REPLACED BY THE MANUFACTURER, ITS SERVICE AGENT OR SIMILARLY QUALIFIED PERSONS IN ORDER TO AVOID A HAZARD.

SAFETY PRECAUTIONS

This unit has been specifically designed to provide protection against personal injury. To ensure continued protection observe the following:

WARNING:

Disconnect power to the unit before servicing following all lock out/tag out procedures established by the user. Verify all of the power is off to the unit before any work is performed.

FAILURE TO DISCONNECT THE POWER COULD RESULT IN SERIOUS INJURY, DEATH OR EQUIPMENT DAMAGE.

CAUTION:

Always be sure to keep area around the unit clean and free of clutter. Failure to keep this area clean may result in injury or equipment damage.

DO NOT STORE EXPLOSIVE SUBSTANCES SUCH AS AEROSOL CANS WITH A FLAMMABLE PROPELLANT IN THIS APPLIANCE.

CHILDREN SHALL NOT PLAY WITH THE APPLIANCE.

SHIPPING AND STORAGE

CAUTION:

Before shipping, storing, or relocating the unit, the unit must be sanitized and all sanitizing solution must be drained from the system. A freezing ambient environment will cause residual sanitizing solution or water remaining inside the unit to freeze resulting in damage to internal components.

MOUNTING IN OR ON A COUNTER

WARNING:

When installing the unit in or on a counter top, the counter must be able to support a weight in excess of 140 lbs. (63.5 kg.) to insure adequate support for the unit.

FAILURE TO COMPLY COULD RESULT IN SERIOUS INJURY, DEATH OR EQUIPMENT DAMAGE.

THE APPLIANCE HAS TO BE PLACED IN A HORIZONTAL POSITION

R290 REFRIGERANT WARNINGS



WARNING! R290 Refrigerant used in this dispenser is flammable. Follow the Warnings listed below to avoid hazards.

⚠ DANGER:

Risk Of Fire or Explosion. Flammable Refrigerant Used. Do Not Use Mechanical Devices To Defrost Refrigerator. Do Not Puncture Refrigerant Tubing.

⚠ DANGER:

Risk Of Fire Or Explosion. Flammable Refrigerant Used. To Be Repaired Only By Trained Service Personnel. Do Not Puncture Refrigerant Tubing.

⚠ CAUTION:

Risk Of Fire Or Explosion. Flammable Refrigerant Used. Consult Repair Manual/Owner's Guide Before Attempting To Install or Service This Product. All Safety Precautions Must be Followed.

⚠ CAUTION:

Risk Of Fire Or Explosion. Flammable Refrigerant Used. Dispose Of Properly In Accordance With Federal Or Local Regulations. Flammable Refrigerant Used.

⚠ CAUTION:

Risk Of Fire Or Explosion Due To Puncture Of Refrigerant Tubing; Follow Handling Instructions Carefully. Flammable Refrigerant Used.

⚠ WARNING:

Do not use electrical appliances inside the food/ice storage compartments unless they are of the type recommended by the manufacturer.

⚠ WARNING:

To reduce flammability hazards the installation of this appliance must only be carried out by a suitably qualified person.

⚠ WARNING:

Any fluid circuits connected to the appliance shall safely release abnormal pressure. It shall not allow the release of flammable refrigerant into areas served by the other circuits if these do not comply with minimum room area limit.

The appliance is to be installed in accordance with the Safety Standard for Refrigeration Systems.

Appliances and their surroundings shall not attain excessive temperatures in normal use.

⚠ WARNING:

Do not use means to accelerate the defrosting process or to clean, other than those recommended by the manufacturer.

The appliance shall be stored in a room without continuously operating ignition sources (for example: open flames, an operating gas appliance or an operating electric heater).

Do not pierce or burn.

Be aware that refrigerants may not contain an odor.

⚠ WARNING:

Keep any required ventilation openings clear of obstruction.

Notice that servicing shall be performed only as recommended by manufacturer.

⚠ CAUTION:

Refrigeration Servicing

Safety should be considered before equipment Service in Field:

During the evacuation test, after achieving a vacuum level of 50 Microns or less, the refrigeration system shall be isolated from the vacuum pump and the pressure shall not rise above 1500 microns within 10 min.

The vacuum pressure level shall be lessor of 50 microns or value required for compliance with national and local codes and standards, which may vary between residential, commercial, and industrial buildings.

UNIT DIMENSIONS

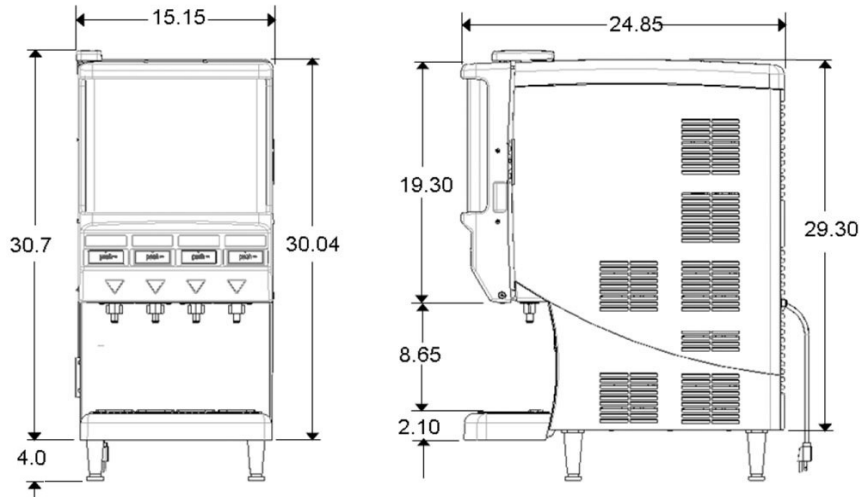

Figure 1. Quest Elite 4FL

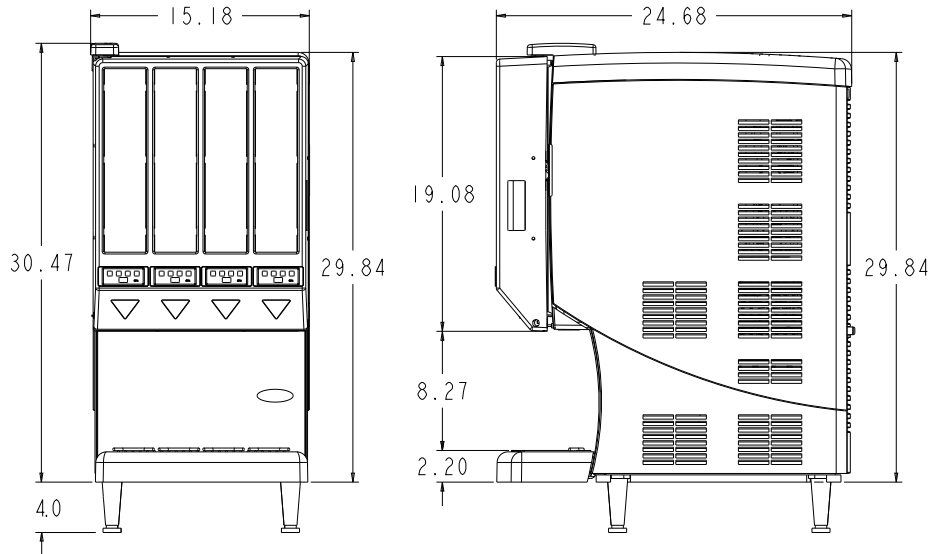

Figure 2 Quest Elite 4FL (Vertical)

RECEIVING

Each unit is completely tested and inspected before shipment. At the time of shipment, the carrier accepts the unit and any claim for damage must be made with the carrier.

Upon receiving the unit(s) from the carrier, inspect the carton for visible damage. If damage exists, have the carrier make a note on the bill of lading and file a claim with the carrier.

UNPACKING

- Remove staples securing carton to pallet.
- Lift carton up and off of unit.
- Remove inserts and shipping bag.
- Open upper cabinet door and remove installation kit.
- Remove bolts securing unit to pallet.
- Lift unit off of pallet.

NOTE: Do not lay the unit on it's side or back. This may cause vital oils to drain from the compressor resulting in damage during start-up and consequently voiding the warranty.

Nameplate Data

Models	VAC	Amps	Ph	Hz	Refrigerant			Test Pressure psi (Kpa) (bar)	
					Oz	Grams	Type	High side	Low side
QST Elite 4FL	115	5	1	60	1.97	56	R-290	282 (1944.3) / 19.4	88 (606.7) (6.1)
QST Elite 4FL (Vertical)	115	5	1	60	1.97	56	R-290	282 (1944.3) / 19.4	88 (606.7) (6.1)
QST Elite 4FL	220/230	2	1	60/50	1.97	56	R-290	289 (1992.6) / 19.9	103(710.2) (7.1)

Concentrate Storage

Four 0.8 gallon (3.0 liter) disposable bottles.

NOTE: Refillable Concentrate reservoirs also available.



Figure 3. Concentrate Storage

Ice Bank/Pull Down

Weight 14-16 lbs. (6.35 - 7.25 kg.). Pull Down: <5.5 hours at 75°F (24°C)

APPLICATIONS

This appliance is intended to be used in household and similar applications such as the following:

- Staff kitchen areas in shops, offices and other working environments.
- Farm houses and by clients in hotels, motels and other residential type environments.
- Bed and breakfast type environments.
- Catering and similar non-retail applications.

INSTALLATION REQUIREMENTS

Counter Location

Select a location in a well ventilated area, close to a grounded electrical outlet. If possible do not place the unit close to hot and/or steaming machines.

Minimum Airflow Clearance

The minimum airflow clearance is: 4" (10.16 cm) in back and at sides; 12" (30.48 cm) on top, 4" (10.16) at sides and open to the front.

IMPORTANT:

Condenser air is drawn in from the bottom of the rear panel and discharged out the top of the rear panel & side panels. Failure to maintain clearance space will reduce capacity of the unit and cause premature compressor failure.

The Dispenser needs to be placed using 4" legs that are included.

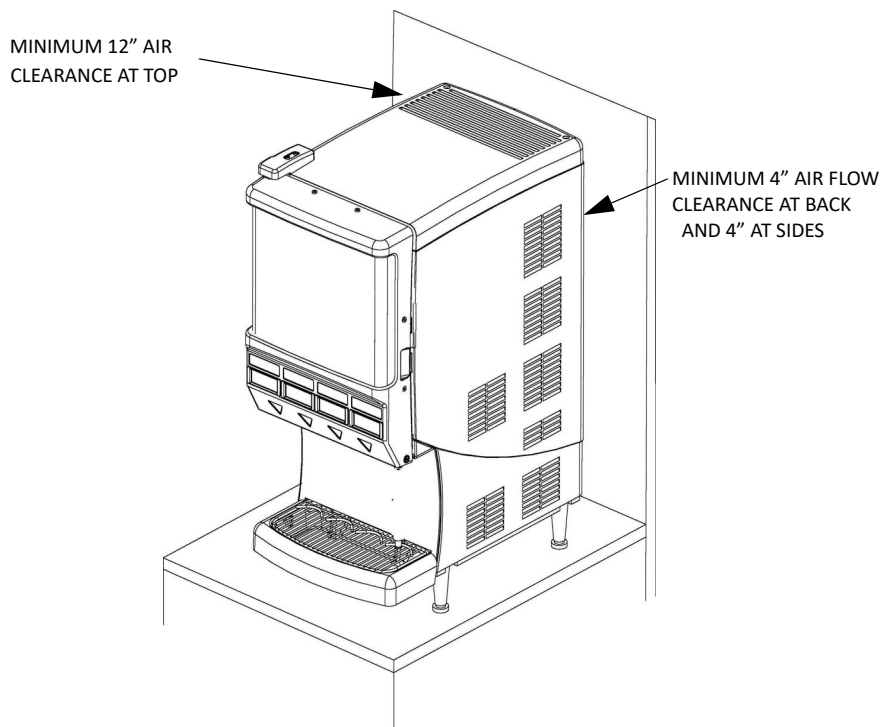

Figure 4. Minimum Clearances

CONNECTING THE WATER SUPPLY

The Quest Elite series Juice Dispenser is designed to dispense juice at a high flow rate. It is very important that the incoming water line be dedicated for use by the dispenser only and does not have other machines connected which could cause a water surge, (i.e., a dishwasher, coffee maker, etc.).

IMPORTANT:

The water supply should be consistent with proper water quality standards (neutral pH of 7.0 to 8.0), and should not be connected to a water softener. It is the installer's responsibility to ensure that all water connections to the dispenser are sized, installed with adequate backflow protection and maintained to comply with Federal, State, and Local Laws.

PLUMBING AND WATER SUPPLY REQUIREMENTS

This dispenser must be connected to a **COLD WATER** system with operating pressure between 30 psi (206.8 kPa) (2.1 bar) minimum (dynamic) and 60 psi (413.7 kPa) (4.1 bar) maximum (static). This water source must be capable of producing a minimum flow rate of 3 fluid ounces (88.7 ml) per second. A shut off valve should be installed in the line before the dispenser. Install a regulator in the line when pressure is greater than 60 psi (413.7 kPa) to reduce it to 50 psi (345 kPa) (3.5 bar) (dynamic). The regulator is also necessary if the water source has pressure fluctuations.

⚠ WARNING:

This equipment must be installed to comply with the International Plumbing Code of the International Code Council and the Food Code Manual of the Food and Drug Administration (FDA). For models installed outside the U.S.A., you must comply with the applicable Plumbing/Sanitation Code for your area.

Failure to comply could result in serious injury, death or damage to the equipment.

1. Secure the 3/8" (0.95 cm) swivel nut on the flexible supply tubing to the water inlet located at the rear of the dispenser. Make sure that the flared gasket is used (flared gasket P/N 311304000 is included with the installation kit).

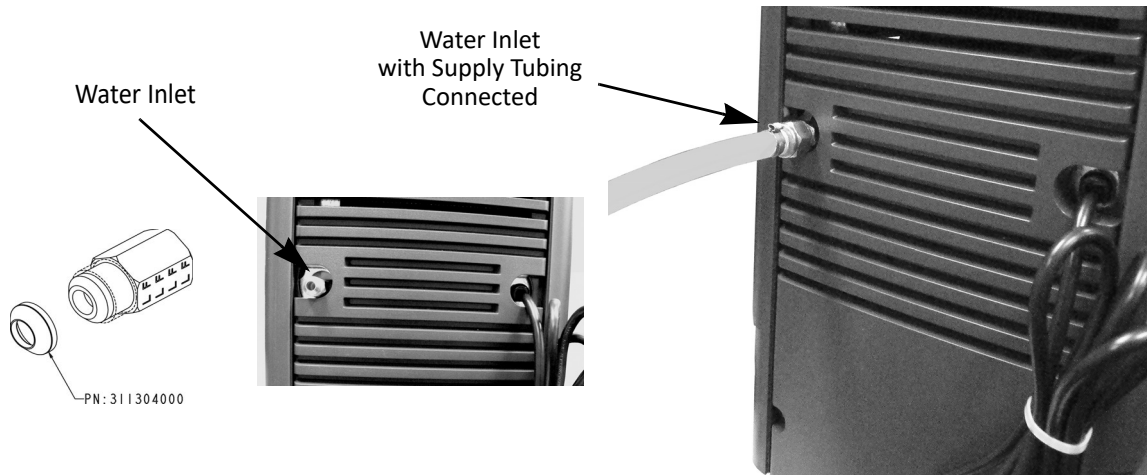

Figure 5. Water Supply Connection On Rear Of Unit

2. When securing flare nut, use a backup wrench on the male side of the inlet fitting (unit side) to prevent twisting of the copper tube inside the unit and/or possible damage to the water strainer/solenoid. Water shut off outside the unit is recommended.

FILLING THE ICE BATH

The ice bath holds approximately 3.5 gallons (13.4 liters) of water. The fill tube is located behind the front splash plate and capped with a 0.5" plug.

1. Remove the 0.5" plug and attach the tube to any one of the dispense nozzles.
2. Open the door and verify that the flush/dispense lever is in the dispense mode. (see Figure 6) Ice bath must always be filled in the dispense mode.

NOTE: Non flush units does not have a flush/dispense lever hence for filling water bath on non flush units please remove the concentrate Storage bottles first and then attach the tube to any one of the dispense nozzles and close the door, press and hold the dispense button (push) until the tank is filled and water trickles from the overflow

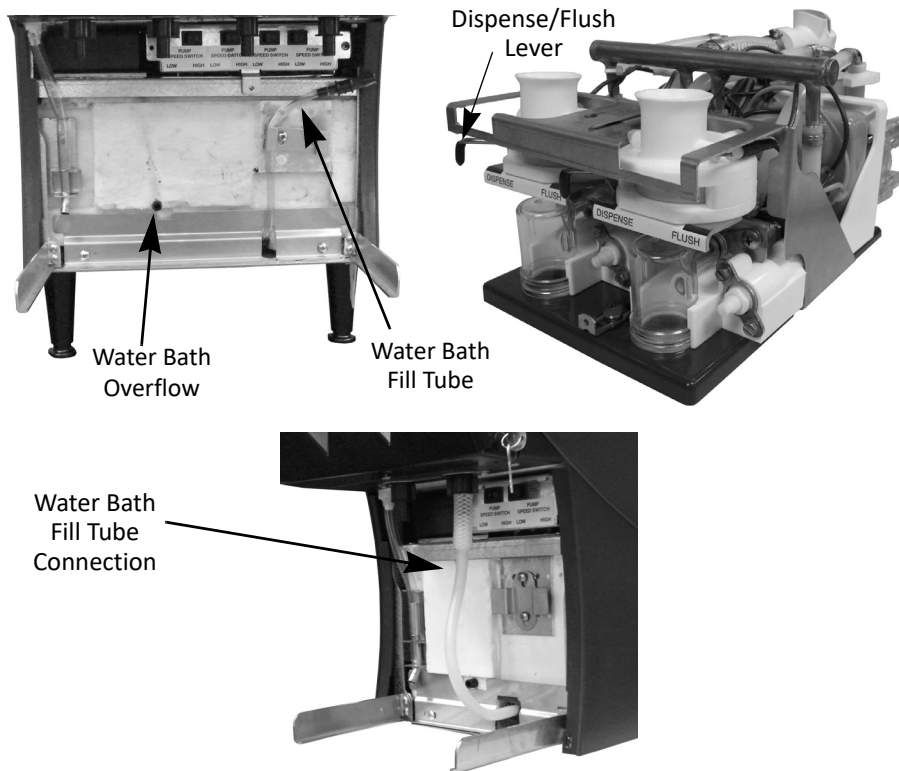

Figure 6. Water Bath and Dispense/Flush Lever

3. Close the door, press and hold the dispense button (push), shown in Figure 7. Dispense Buttons, until the tank is filled and water trickles from the overflow.



Figure 7. Dispense Buttons

4. Once the ice bath is full, store the fill tube in the vertically recessed holder. The fill tube can now be used as a "sight glass" to monitor the water level in the ice bath.

ELECTRICAL REQUIREMENTS

⚠ CAUTION:

Only trained and certified electrical technicians should replace the power cord or the unit should be returned to an Authorized Service Center for power cord replacement.” The replacement cord must meet all requirements of the original equipment manufacturer.

FAILURE TO COMPLY COULD RESULT IN SERIOUS INJURY, DEATH OR DAMAGE TO THE EQUIPMENT.

1. A minimum of 15 amps electrical service is needed for 120VAC power supply. A minimum of 10 amps electrical service is needed for 230VAC power supply.
2. 6 ft. long (1.83 m) power cord with 3-prong plug attached to dispenser. Export models are shipped with a European plug.

⚠ WARNING:

When positioning the appliance, ensure the supply cord is not trapped or damaged.

Do not locate multiple portable socket-outlets or portable power supplies at the rear of the appliance.

PRIMING/FLUSHING WATER SYSTEM

To properly prime the unit with water and remove air pockets in the system, open the cabinet door and make sure that all the valve levers are in the **Dispense** position.

Close the door and press the dispense button for a few seconds. Repeat until a steady flow of water is observed from all dispense valves.

NOTE: Some splashing may occur during this purge cycle.

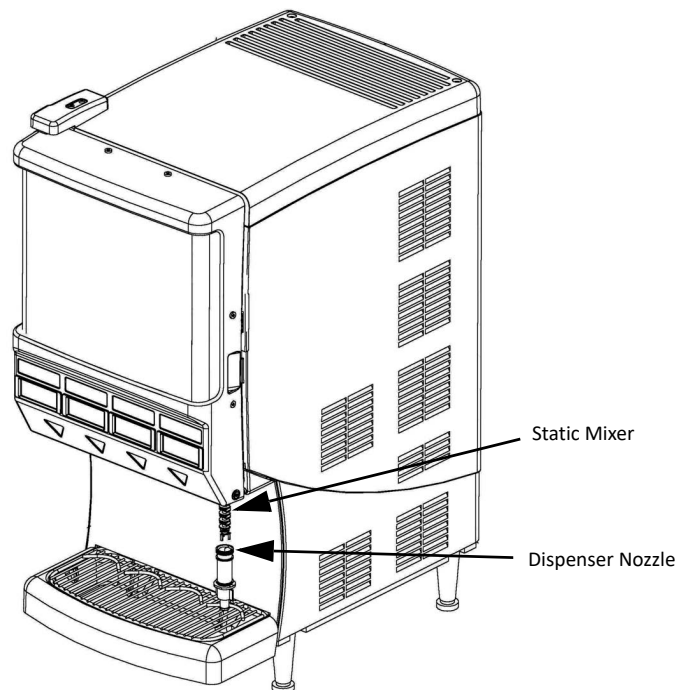

Figure 8. Dispense Nozzle

CONCENTRATE HANDLING AND LOADING

It is recommended that the concentrate be thawed in a refrigerated 35°F to 40°F (1.6°C to 4.4°C) compartment for a minimum of 48 hours prior to loading it into the Quest Juice Dispenser.

WARNING:

Concentrate must be completely thawed and within the temperature range of 35°F to 40°F (1.6°C to 4.4°C) prior to loading. Failing to supply concentrate inside the recommended temperature range, especially below 35°F (1.6°C), causes an out of BRIX drink (refer to the BRIXING Procedure section for details).

LOADING CONCENTRATE

The Quest Juice Dispenser is designed to use either disposable juice concentrate containers or the optional Cornelius generic refillable container (sold separately).



Figure 9. Refillable Concentrate Container

1. Thoroughly shake concentrate container prior to use.
2. Place concentrate containers on the dispensing platform shelf inside the refrigerated cabinet.
3. Engage the concentrate container by pressing it downward into the bottle adapter opening on the dispensing platform.
NOTE: Be sure to lubricate the o-ring seal on the container nozzle. This ensures a good seal and allows the pumps to draw concentrate from the containers more easily. Failure to create a good seal at this connection may result in weak drinks and/or seepage of concentrate.
4. Prime each pump by closing the cabinet door and press each dispense button until concentrate flows from the dispense nozzles.

CHANGING CONCENTRATE CONTAINERS

1. Open the cabinet door and move the valve handle from the **Dispense** to **Flush** position, see Figure 10.

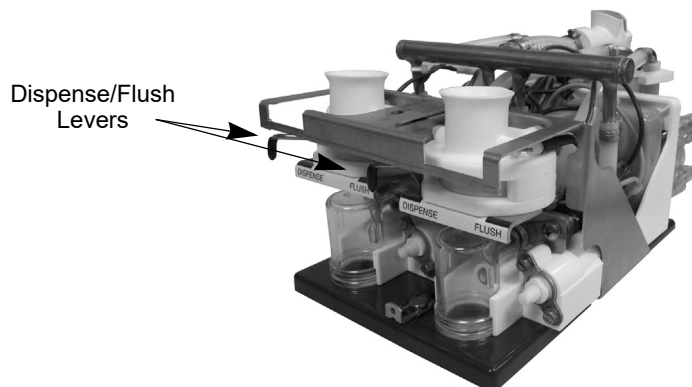

Figure 10. Dispense/Flush Lever Location

2. Close the door. Depress and hold the dispense button (Figure 11) until clear water flows from the dispense nozzle.

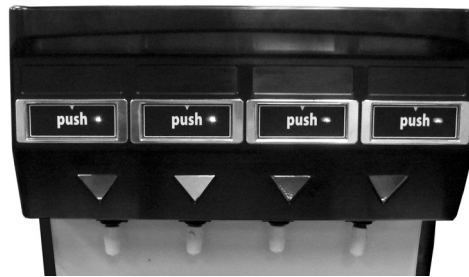

Figure 11. Dispense Buttons

3. Open the cabinet door and return the handle to the **Dispense** position.
4. Depress and hold the dispense button for 1-2 seconds. This relieves water pressure from the concentrate pump system.
 1. Load the concentrate container (see Figure 12)



Figure 12. Loading a Concentrate Container



BRIXING PROCEDURE

NOTE: If concentrate is not properly thawed, it will adversely affect the amount of concentrate dispensed. Thawed product should be between 35°F/1.6°C to 40°F/4.4°C.

SUPPLIES

- 1 - Small 12 oz. cup (354.8 ml)
- 1 - Large 21 oz. cup (621.1 ml)
- 1 - Straw
- Paper Towels
- 1 - Thermometer
- 1 - Refractometer
- 1 - Flat Bladed Screwdriver

NOTE: Refractometer P/N 511004000 is available through your local Cornelius Distributor.

CHECKING/ADJUSTING THE BRIX SETTING

The following instructions are for use with a refractometer.

1. Dispense approximately 8 oz. (237 ml) of drink and discard. Now draw a second 8 oz. (237 ml) drink.
2. Check drink temperature with a accurate thermometer (target is 35 to 45°F, or 1.6 to 7.2°C). Discard this drink after checking temperature.

NOTE: If drink temperature is not within the target range, refer to the basic troubleshooting section.

3. Dispense a 12 oz (354.8 ml) drink sample into a clean, 21 oz (621.ml) dry cup. Thoroughly stir the sample using a straw.
4. Using the straw, transfer a small sample of the finished drink to the refractometer lens (refer to operating instructions supplied with your refractometer). Check the BRIX reading against the BRIX chart in Table 2.

NOTE: The BRIX chart shown in Table 2 is generic and intended for reference use only. Contact your frozen concentrate supplier for specific BRX readings.

Table 1.

Flavor	Ratio	BRIX
Orange Juice	4+1	11.8
Grapefruit Juice	5+1	10.6
Cranberry Cocktail	4+1	13.5
Apple Juice	5+1	12.0
Grape	5+1	13.0
Lemonade	5+1	10.5
Tropical Punch	5+1	11.8
Sweetened Ice Tea	7+1	6.0
Pineapple Juice	4+1	12.8
Prune Juice	2+1	16.0

5. To change the BRIX setting, simply re-adjust the water flow rate. Located on each of the valve assemblies inside the refrigerated compartment are the adjusting screws for the water flow rate (one per valve).

f the BRIX reading is too high or low, rotate the appropriate water flow control according to Figure 13. Repeat steps 1-5 until the proper BRIX setting is achieved.

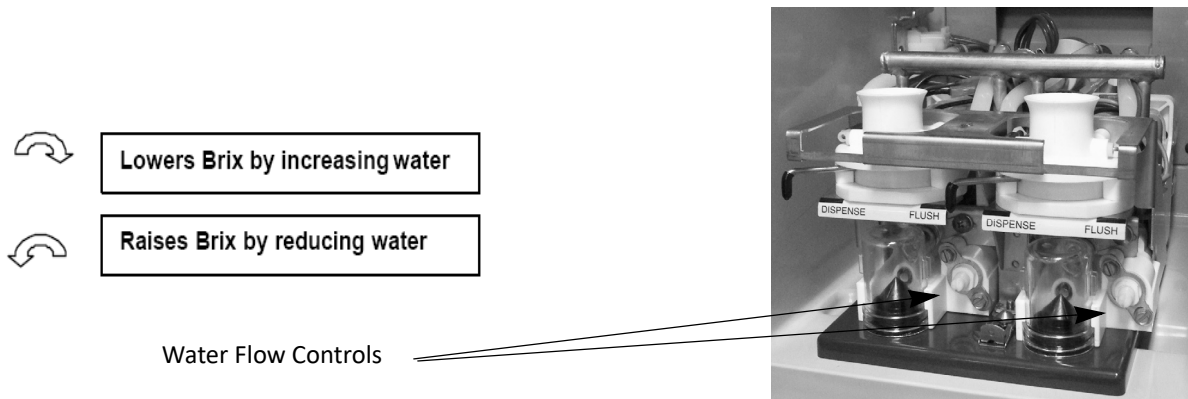

Figure 13.

IMPORTANT: When making changes to the water flow control, do not rotate more than 1/4 turn per adjustment. Additionally, prior to taking your next BRIX reading, momentarily press the corresponding dispense button several times prior to drawing a sample. This clears any remnants from the dispense nozzle and helps move the flow control to its new setting.

PROGRAMMING THE PORTION CONTROL

If the dispenser has optional portion controls, they have been pre-programmed from the factory to pour 7, 12, and 16 ounce drinks. The “extra large” (pitcher icon) size has also been pre-programmed to pour 16 ounces.

To change the pour sizes, please perform the procedure described in .

Table 2.

Step	Action
1	Simultaneously, press and hold Small and Extra Large buttons on the Portion Control Module until the Refill light starts blinking. Release the buttons. The blinking Refill light indicates the programming mode is active. See . Control Panel.
2	Place a cup under the dispense nozzle and push the selected size button (small, medium, large, or extra large). Hold the button in until the cup fills to the desired portion, then release the button. Repeat the procedure for the remaining sizes.
3	After programming all the drink sizes, press and release the Stop button to return the Portion Control to the operational mode. The blinking REFILL light goes off.
4	In the future, to change the portion size of the drinks, the individual sizes can be adjusted by performing Step 2. It is not necessary to reprogram every size. Additionally, the portion control has full memory retention in case of a power failure.

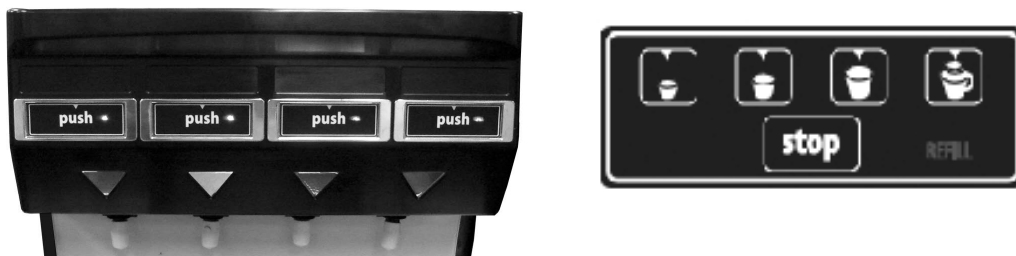

Figure 14. Control Panel

STOP BUTTON

To pour a drink without using a pre-programmed portion control size, simply push and hold the Stop button. Release when the glass is full.

PLANNED MAINTENANCE SCHEDULE

DAILY

Flush System

1. Move all of the Dispense/Flush levers (located on the platform assembly in the refrigerated cabinet) to the **Flush** position. Place an empty cup on the drip tray below each dispense nozzle (Figure 15).

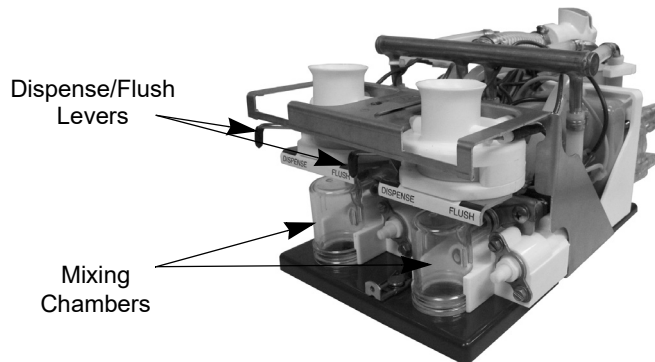

Figure 15. Platform Assembly with Dispense/Flush Levers

2. Close the door and depress each dispense button for 2-3 seconds or until clear water flows from each dispense nozzle.



Figure 16. Dispense Buttons

3. Return the Dispense/Flush levers to the **Dispense** position.
4. Press each Dispense button for 1 to 2 seconds to release the water pressure present in the concentrate pump system.

Clean Splash Zones & Dispense Nozzles

1. On a daily basis, using a clean, damp cloth, clean the external cabinet and splash areas including the door gasket. Remove and wash the cup rest and drip tray using mild dish soap.
2. Remove the dispense nozzles and static mixers by rotating each 90° and pulling down. Remove the mixing chambers by pulling straight forward. Wash using mild dish soap.

IMPORTANT: DO NOT wash nozzles, static mixers, or mixing chambers in a dish washer. This will distort the plastic and damage the o-rings. Additionally, do not soak them in sanitizing solution longer than 2 minutes.

Flush once a day for better quality drinks.



WARNING:

Do not leave the unit in FLUSH mode. Leaving the unit in flush mode may result in damage.

WEEKLY

Check concentrate to water brix ratio (refer to the Checking/Adjusting the See “BRIXING Procedure” on page 13.).

Sanitize the Juice Dispenser

1. Rinse the unit with hot water.
2. Prepare two 2 oz. (59 ml) packets of Stera-Sheen Green Label sanitizing solution (or similar brand) by dissolving each packet in 1 gallon (3.8L) of potable water to insure 200 ppm of available chlorine.

IMPORTANT: Use potable water at 80°F-100°F (26.7°C-37.8°C). Water above this range breaks down the chlorine count and minimizes sanitation.
3. Remove the juice concentrate containers and place them in separate refrigerated compartment.
4. Flush the system by following the instructions in See “Flush System” on page 15..
5. Fill a clean empty concentrate container with one quart of extremely hot tap water, approximately 140°F (60°C) and place the container into the unit. Dispense all of the hot water into a large container. Repeat for all the remaining dispense valves.
6. Remove the mixing chambers, nozzles, and static mixers. Rinse in hot water to remove excess pulp and concentrate.
7. Place the mixing chambers, nozzles, and static mixers in a separate container of sanitizing solution and agitate vigorously. Allow the parts to soak for two minutes, then rinse thoroughly with fresh tap water.
8. Reinstall the static mixer, nozzles, and mixing chambers

Sanitize Pump System

1. Fill a clean concentrate container with 2 quarts (1.9L) of fresh sanitizing solution.
2. Place Dispense/Flush levers (located on the platform assembly in the refrigerated cabinet) to the **Dispense** position.and close the door.

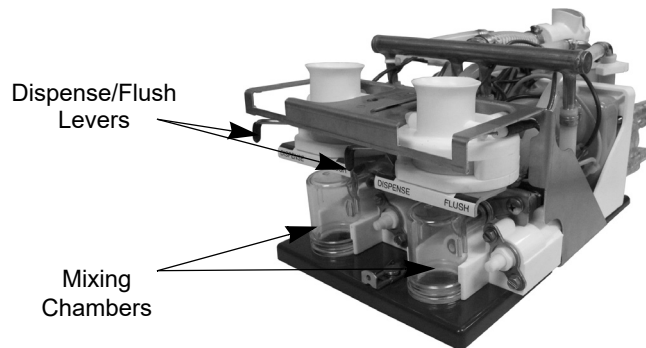

Figure 17. Dispense/Flush Levers

3. Press and hold the dispense button for 90 seconds then release. Allow sanitizing solution to remain in the lines for 5 minutes.



Figure 18. Dispense Buttons

4. After 5 minutes, dispense the remaining sanitizing solution.

Prepare Dispenser for Use

1. Replace sanitizing solution container with a concentrate container and close the door.
2. Press and hold the dispense button until juice appears from the nozzle. Next dispense and discard at least two 8 oz. (236.6ML) cups of juice in order to prime the system and prepare it for operation.

SEMI ANNUALLY

CAUTION:

The following procedures require removal of the dispenser side panel(s). Disconnect the power cord (See Figure 19.) from the receptacle prior to proceeding.



Figure 19. Pull AC Plug from Wall Outlet

Clean Water Inlet Strainer

1. Remove the top and rear panels; then remove right-side panel from the dispenser.
2. Turn off the water supply to the dispenser.
3. Remove the access port from the “Y” shaped water inlet solenoid located on the right side of the dispenser. (See Figure 20)
4. Clean and reinstall the stainless steel water strainer.



Figure 20. Right Side of Dispenser

Clean Chassis Interior

1. Clean the condenser cooling fins.
2. Clean the air inlet grilles located on the rear and top panels of the dispenser.
3. Clean the interior base.
4. Wipe the fan blades clean.
5. Reinstall the right side panel, turn on the water supply, and plug the dispenser into the power receptacle.

Check and Top-Off Water Ice Bath

1. Remove the drip tray and lower splash panel.



Figure 21. Drip Tray and Cup Rest

If the Ice bath level is below the **FULL** indicator, top it off with water. Refer page 9 for the ice bath procedure

ANNUALLY

Replace Pump Tubing and Clean Cabinet

A replacement pump tubing kit, part # 45098, is available. The kit consists of one pre-cut length of pump tubing, two white plastic hose clamps, and instructions.

Removing Pump Platform(s)

1. Remove the concentrate containers from the dispenser and place them in a refrigerator.
2. Remove the cabinet shelf that the concentrate containers sit on.
3. Flush the system prior to removing the pump platform (refer to the Daily). Remove the dispense nozzles and static mixers.
4. Unplug the water line quick disconnect by pressing the gray button (See Figure 22).

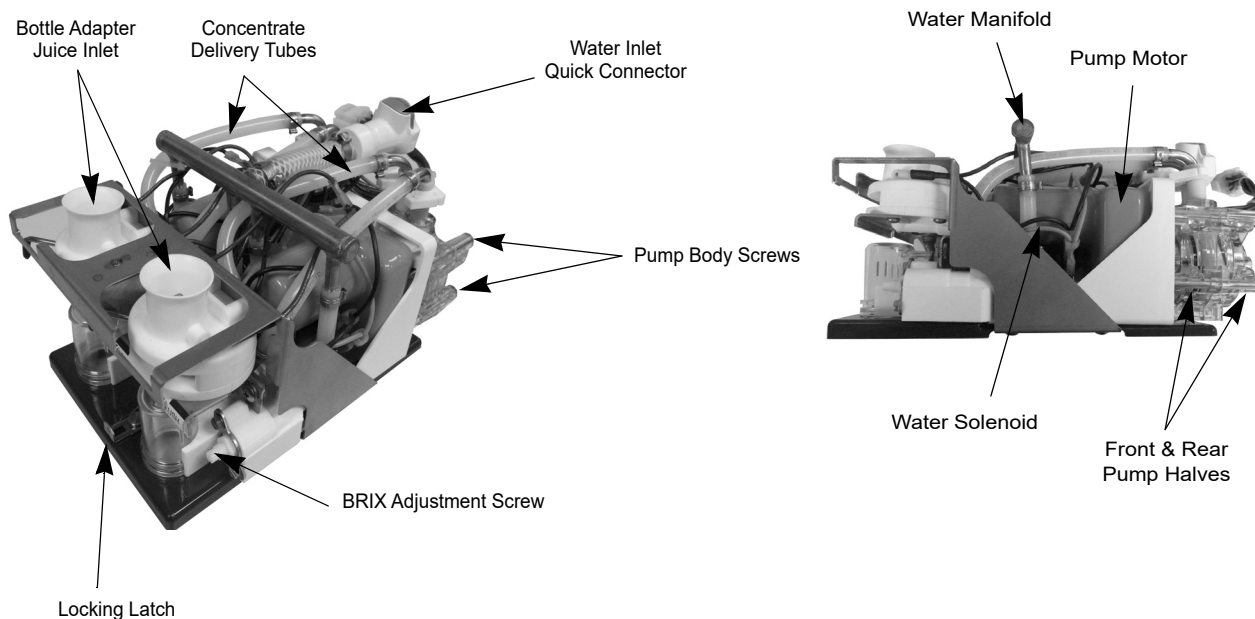

Figure 22. Interior Details

5. Slide the locking latch forward. Lift the platform slightly and pull forward to gain access to the electrical connector (see Figure 22).

- Unplug the electrical connector by squeezing the locking tabs on either side and pulling out the connector. Lift and remove the pump platform (see Figure 22).

Replacing the Tubing

When the pump platform has been removed, replace the tubing by performing the following procedure.

- Remove the two white plastic hose clamps from the pump tube connections (See Figure 22) and remove the concentrate delivery tubes from the hose ends.
- Loosen and remove the four screws from the pump body (See Figure 23).

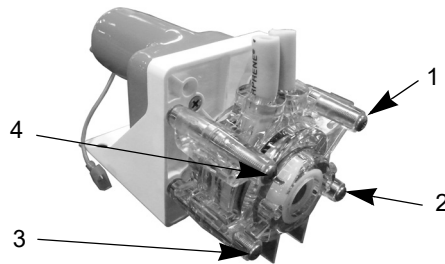

Figure 23. Pump Body Screws

- Remove **ONLY** the rear pump body half to reveal the pump tubing and rollers (See Figure 24).
- Remove the old pump tubing from the pump body. If the roller assembly comes out with the tubing, place it back into the pump housing. **Make sure to align the roller assembly shaft key way to the motor shaft so that the two interlock.**
- Firmly press the new tubing into the pump body around the roller assembly, making sure to keep the protruding ends even with each other.
- Once the tubing is in place, hold the tubing with one hand, capture the lower part of the tubing with the outer housing, then proceed to capture the shaft of the roller assembly and push the rear pump housing into place. Make sure to capture the tubing within the body and not pinch it between the halves. Do not use any tool other than your finger tips to manipulate the tubing into the housing or you may damage the tubing.

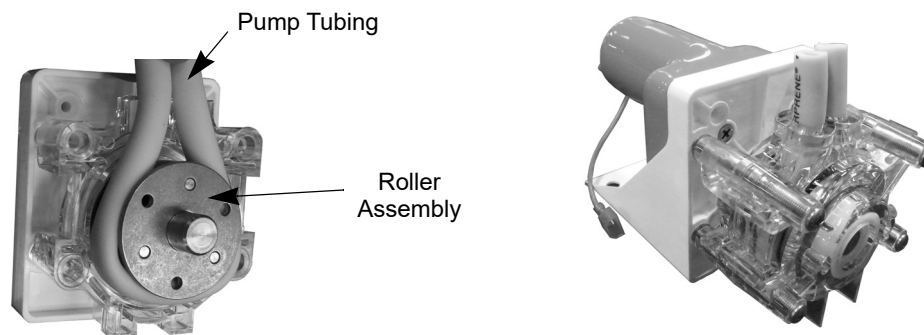

Figure 24. Pump Assembly

- While holding the pump halves together with your hand, reinsert the four thumb screws (See Figure 23) and tighten using a criss-cross pattern as shown. The thumb screws should be tightened about 1/4 turn beyond snug.
- Insert the two concentrate delivery tubes into the pump tubing ends and secure them using the new hose clamps supplied in the kit. Be sure to use pliers to squeeze and tighten the hose clamps.

Cleaning the Cabinet

The cabinet bottom surface and walls should be inspected and cleaned annually according to the following steps:

1. Remove natural rubber nozzle bushing gasket (see Figure 25) and inspect it and silicone RTV. If cracked, clean off RTV, and re-apply using kit P/N 729011013 per instructions provided with kit.
2. Re-apply nozzle bushing gasket so that the edges lie flat on the floor of the cabinet.

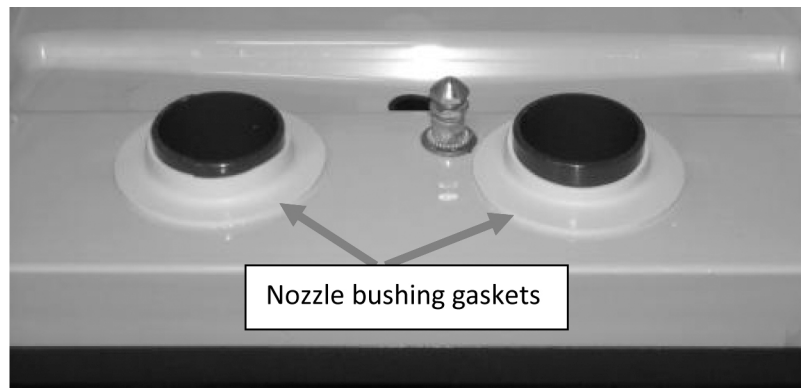

Figure 25. Nozzle bushing gaskets - proper installation

3. Clean cabinet floor and walls of any spilled juice and let dry. Use a mild soap/detergent and plain water.
4. Reinstall the pump platform in the reverse order given above.

Long-term Storage

If the unit is going to be left empty for a long period of time, prepare the unit according to the following steps:

1. Turn off the unit.
2. Allow the water bath to defrost. Once defrosted, empty the water from the water bath.
3. Clean the cabinet and surfaces of the unit.
4. Dry the cabinet and surfaces of the unit.
5. Leave the cabinet door open to prevent mold developing within the cabinet.



QUEST ELITE 4FL SERVICE PROCEDURES



[BLANK]



SPECIALIZED PRECAUTIONS AND GUIDELINES FOR SERVICING UNITS USING R290 REFRIGERANT

Qualification of Service Personnel/Workers

Required qualification of working personnel for maintenance, service and repair operations. Every working procedure that affects safety means shall only be carried out by competent persons.

Examples for such working procedures are:

- Breaking into the refrigerating circuit.
- Opening of sealed components.
- Opening of ventilated enclosures.

Information on Servicing

- Prior to beginning work on systems containing FLAMMABLE REFRIGERANTS, safety checks are necessary to ensure that the risk of ignition is minimized.
- For repair to the REFRIGERATING SYSTEM, above steps shall be completed prior to conducting work on the system.

Work Procedure

Work shall be performed under a controlled procedure so as to minimize the risk of a flammable gas or vapor being present while the work is being performed.

General Work Area

All maintenance staff and others working in the local area shall be instructed on the nature of work being carried out. Work in confined spaces shall be avoided.

Checking for Presence of Refrigerant

The area shall be checked with an appropriate refrigerant detector prior to, and during work, to ensure the technician is aware of potentially toxic or flammable atmospheres.

Ensure that the leak detection equipment being used is suitable for use with all applicable refrigerants, i.e. non-sparking, adequately sealed or intrinsically safe.

Presence of Fire Extinguisher

If any hot work is to be conducted on the refrigerating equipment or any associated parts, appropriate fire extinguishing equipment shall be available to hand. Have a dry chemical or CO₂ fire extinguisher adjacent to the charging area.

No Ignition Sources

No person carrying out work in relation to a REFRIGERATING SYSTEM which involves exposing any pipe work shall use any sources of ignition in such a manner that it may lead to the risk of fire or explosion.

All possible ignition sources, including cigarette smoking, should be kept sufficiently far away from the site of installation, repairing, removing and disposal, during which refrigerant can possibly be released to the surrounding space. Prior to work taking place, the area around the equipment is to be surveyed to make sure that there are no flammable hazards or ignition risks. "No Smoking" signs shall be displayed.

Ventilated Area:

Ensure that the area is in the open or that it is adequately ventilated before breaking into the refrigeration system or conducting any hot work. A degree of ventilation shall continue during the period that the work is carried out. The ventilation should safely disperse any released refrigerant and preferably expel it externally into the atmosphere.

Checks to the Refrigeration Equipment

Where electrical components are being changed, they shall be fit for the purpose and to the correct specification. At all times the manufacturer's maintenance and service guidelines shall be followed. If in doubt, consult the manufacturer's technical department for assistance.

The following checks shall be applied to installations using FLAMMABLE REFRIGERANTS:

The actual REFRIGERANT CHARGE is in accordance with the room size within which the refrigerant containing parts are installed.

The ventilation machinery and outlets are operating adequately and are not obstructed.

If an indirect refrigerating circuit is being used, the secondary circuit shall be checked for the presence of refrigerant.

Marking to the equipment continues to be visible and legible. Markings and signs that are illegible shall be corrected.

Refrigerating pipe or components are installed in a position where they are unlikely to be exposed to any substance which may corrode refrigerant containing components, unless the components are constructed of materials which are inherently resistant to being corroded or are suitably protected against being so corroded.

Checks to Electrical Devices

Repair and maintenance to electrical components shall include initial safety checks and component inspection procedures. If a fault exists that could compromise safety, then no electrical supply shall be connected to the circuit until it is satisfactorily dealt with. If the fault cannot be corrected immediately but it is necessary to continue operation, an adequate temporary solution shall be used. This shall be reported to the owner of the equipment so all parties are advised.

Initial safety checks shall include and ensure:

that capacitors are discharged: this shall be done in a safe manner to avoid possibility of sparking, using a Supco CapDis tool;

that no live electrical components and wiring are exposed while charging, recovering or purging the system;

that there is continuity of earth bonding.

Repairs to Sealed Components

During repairs to sealed components, all electrical supplies shall be disconnected from equipment being worked upon prior to any removal of sealed covers, etc. If it is absolutely necessary to have an electrical supply to equipment during servicing, then a permanently-operating form of leak detection shall be located at the most critical point to warn of a potentially hazardous situation.

Particular attention shall be paid to the following to ensure that by working on electrical components, the casing is not altered in such a way that the level of protection is affected. This shall include damage to cables, excessive number of connections, terminals not made to original specification, damage to seals, incorrect fitting of glands, etc.

Ensure that the apparatus is mounted securely.

Ensure that seals or sealing materials have not degraded to the point that they no longer serve the purpose of preventing the ingress of flammable atmospheres. Replacement parts shall be in accordance with the manufacturer's specifications.

Repair to Intrinsically Safe Components

Do not apply any permanent inductive or capacitance loads to the circuit without ensuring that this will not exceed the permissible voltage and current permitted for the equipment in use.

Intrinsically safe components are the only types that can be worked on while live in the presence of a flammable atmosphere. The test apparatus shall be at the correct rating.

Replace components only with parts specified by the manufacturer. Other parts may result in the ignition of refrigerant in the atmosphere from a leak.

NOTE: The use of silicon sealant can inhibit the effectiveness of some types of leak detection equipment. Intrinsically safe components do not have to be isolated prior to working on them.

Cabling

Check that cabling will not be subject to wear, corrosion, excessive pressure, vibration, sharp edges or any other adverse physical or environmental effects. The check shall also take into account the effects of aging or continual vibration from sources such as compressors or fans.

Detection of Flammable Refrigerants

Under no circumstances shall potential sources of ignition be used in the searching for or detection of refrigerant leaks.



CAUTION:

Risk Of Fire Or Explosion Due To Open Flame. A halide torch (or any other detector using a naked flame) shall not be used.

The following leak detection methods are deemed acceptable for all refrigerant systems:

Electronic leak detectors may be used to detect refrigerant leaks but, in the case of FLAMMABLE REFRIGERANTS, the sensitivity may not be adequate, or may need re-calibration. (NOTE: Detection equipment shall be calibrated in a refrigerant-free area.) Ensure that the detector is not a potential source of ignition and is suitable for the refrigerant used. Leak detection equipment shall be set at a percentage of the LFL of the refrigerant and shall be calibrated to the refrigerant employed, and the appropriate percentage of gas (25% maximum) is confirmed.

Leak detection fluids are also suitable for use with most refrigerants but the use of detergents containing chlorine shall be avoided as the chlorine may react with the refrigerant and corrode the copper pipe-work.



CAUTION:

Avoid the use of dish-washing soap/water as a leak-detection fluid.

NOTE Examples of leak detection fluids are:

- bubble method
- fluorescent method agents

If a leak is suspected, all naked flames shall be removed/extinguished.

If a leakage of refrigerant is found which requires brazing, all of the refrigerant shall be recovered from the system, or isolated (by means of shut off valves) in a part of the system remote from the leak.

Removal and Evacuation

When breaking into the refrigerant circuit to make repairs – or for any other purpose – conventional procedures shall be used. However, for flammable refrigerants it is important that best practices be followed since flammability is a consideration. The following procedure shall be adhered to:

- a) safely remove refrigerant following local and national regulations
- b) purge the circuit with inert gas
- c) evacuate
- d) purge with inert gas
- e) open the circuit by cutting or brazing

The refrigerant charge shall be recovered into the correct recovery cylinders if venting is not allowed by local and national codes. For appliances containing flammable refrigerants, the system shall be purged with oxygen-free nitrogen to render the appliance safe for flammable refrigerants. This process might need to be repeated several times. Compressed air or oxygen shall not be used for purging refrigerant systems.

For appliances containing flammable refrigerants, refrigerants purging shall be achieved by breaking the vacuum in the system with oxygen-free nitrogen and continuing to fill until the working pressure is achieved, then venting to atmosphere, and finally pulling down to a vacuum. This process shall be repeated until no refrigerant is within the system. When the final oxygen-free nitrogen charge is used, the system shall be vented down to atmospheric pressure to enable work to take place.

Ensure that the outlet for the vacuum pump is not close to any potential ignition sources and that ventilation is available.

Charging Procedures

In addition to conventional charging procedures, the following requirements shall be followed.

WARNING:

Ensure that contamination of different refrigerants does not occur when using charging equipment. Hoses or lines shall be as short as possible to minimize the amount of refrigerant contained in them.

WARNING:

Cylinders shall be kept in an appropriate position according to the instructions.

WARNING:

Ensure that the REFRIGERATING SYSTEM is earthed prior to charging the system with refrigerant.

WARNING:

Label the system when charging is complete (if not already).

WARNING:

Extreme care shall be taken not to overfill the REFRIGERATING SYSTEM.

Prior to recharging the system, it shall be pressure-tested with the appropriate purging gas. The system shall be leak-tested on completion of charging but prior to commissioning. A follow-up, leak test shall be carried out prior to leaving the site.

UNIT SPECIFICATIONS

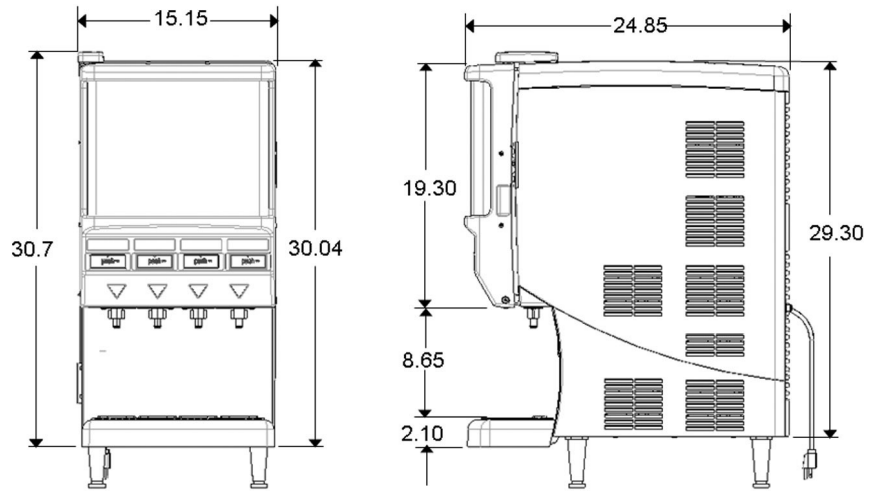

Figure 26. Unit Dimensions

CONCENTRATE HANDLING AND LOADING

It is recommended that the concentrate be thawed in a refrigerated 35°F to 40°F (1.6°C to 4.4°C) compartment for a minimum of 48 hours prior to loading it into the Quest Juice Dispenser.

WARNING:

Concentrate must be completely thawed and within the temperature range of 35°F to 40°F (1.6°C to 4.4°C) prior to loading. Failing to supply concentrate inside the recommended temperature range, especially below 35°F (1.6°C), causes an out of BRIX drink (refer to the BRIXing Procedure section for details).

LOADING CONCENTRATE

The Quest Juice Dispenser is designed to use either disposable juice concentrate containers or the optional Cornelius generic refillable container (sold separately).



Figure 27. Refillable Concentrate Container

1. Thoroughly shake concentrate container prior to use.
 2. Place concentrate containers on the dispensing platform shelf inside the refrigerated cabinet.
 3. Engage the concentrate container by pressing it downward into the bottle adapter opening on the dispensing platform.
NOTE: Be sure to lubricate the o-ring seal on the container nozzle. This ensures a good seal and allows the pumps to draw concentrate from the containers more easily. Failure to create a good seal at this connection may result in weak drinks and/or seepage of concentrate.
 4. Prime each pump by closing the cabinet door and press each dispense button until concentrate flows from the dispense nozzles.
-

Concentrate Storage

Four 0.8 gallon (3.0 liter) disposable bottles.



CHANGING CONCENTRATE CONTAINERS

1. Open the cabinet door and move the valve handle from the **Dispense** to **Flush** position, see Figure 10.

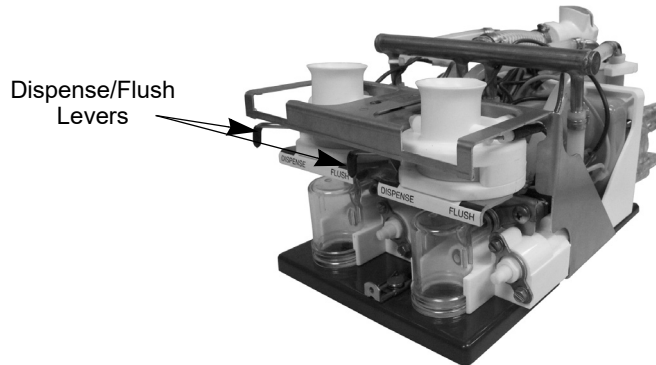

Figure 28. Dispense/Flush Lever Location

2. Close the door. Depress and hold the dispense button (Figure 11) until clear water flows from the dispense nozzle.



Figure 29. Dispense Buttons

3. Open the cabinet door and return the handle to the **Dispense** position.
4. Depress and hold the dispense button for 1-2 seconds. This relieves water pressure from the concentrate pump system.
5. Load the concentrate container (see Figure 12)



Figure 30. Loading a Concentrate Container



BRIXING PROCEDURE

NOTE: If concentrate is not properly thawed, it will adversely affect the amount of concentrate dispensed. Thawed product should be between 35°F/1.6°C to 40°F/4.4°C.

SUPPLIES

- 1 - Small 12 oz. cup (354.8 ml)
- 1 - Large 21 oz. cup (621.1 ml)
- 1 - Straw
- Paper Towels
- 1 - Thermometer
- 1 - Refractometer
- 1 - Flat Bladed Screwdriver

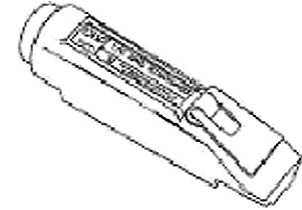

NOTE: The refractometer shown is P/N 511004000, and is available through your local Cornelius Distributor.

CHECKING/ADJUSTING THE BRIX SETTING

The following instructions are for use with a refractometer.

1. Dispense approximately 8 oz. (237 ml) of drink and discard. Now draw a second 8 oz. (237 ml) drink.
2. Check drink temperature with a accurate thermometer (target is 35 to 45°F, or 1.6 to 7.2°C). Discard this drink after checking temperature.

NOTE: If drink temperature is not within the target range, refer to the basic troubleshooting section.

3. Dispense a 12 oz (354.8 ml) drink sample into a clean, dry cup. Thoroughly stir the sample using a straw.
4. Using the straw, transfer a small sample of the finished drink to the refractometer lens (refer to operating instructions supplied with your refractometer). Check the BRIX reading against the BRIX chart shown in Table 3.

NOTE: The BRIX chart shown in Table 3 is generic and intended for reference use only. Contact your frozen concentrate supplier for specific BRX readings.

Table 3.

Flavor	Ratio	BRIX
Orange Juice	4+1	11.8
Grapefruit Juice	5+1	10.6
Cranberry Cocktail	4+1	13.5
Apple Juice	5+1	12.0
Grape	5+1	13.0
Lemonade	5+1	10.5
Tropical Punch	5+1	11.8
Sweetened Ice Tea	7+1	6.0
Pineapple Juice	4+1	12.8
Prune Juice	2+1	16.0

5. To change the BRIX setting, simply readjust the water flow rate. Located on each of the valve assemblies inside the refrigerated compartment are the adjusting screws for the water flow rate (one per valve).

If the BRIX reading is too high or low, rotate the appropriate water flow control according to Figure 31. Repeat steps 1-5 until the proper BRIX setting is achieved.

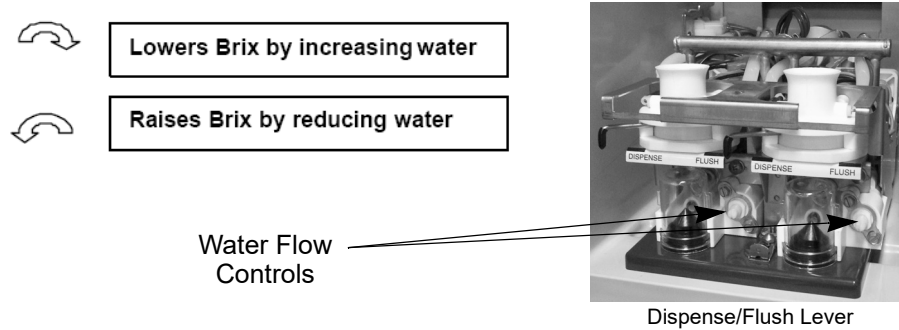

Figure 31. BRIX Adjustment

IMPORTANT: When making changes to the water flow control, do not rotate more than 1/4 turn per adjustment. Additionally, prior to taking your next BRIX reading, momentarily press the corresponding dispense button several times prior to drawing a sample. This clears any remnants from the dispense nozzle AND helps move the flow control to its new setting.

PLANNED MAINTENANCE SCHEDULE

DAILY

Flush System

1. Move all of the Dispense/Flush levers (located on the platform assembly in the refrigerated cabinet) to the **Flush** position. Place an empty cup on the drip tray below each dispense nozzle (Figure 15).

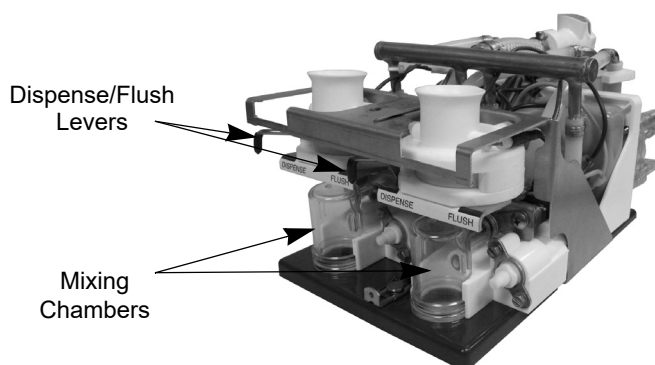

Figure 32. Platform Assembly with Dispense/Flush Levers

2. Close the door and depress each dispense button for 2-3 seconds or until clear water flows from each dispense nozzle.



Figure 33. Dispense Buttons

3. Return the Dispense/Flush levers to the **Dispense** position.
4. Press each Dispense button for 1 to 2 seconds to release the water pressure present in the concentrate pump system.



Clean Splash Zones & Dispense Nozzles

1. On a daily basis, clean the external cabinet and splash areas using a clean damp cloth. Remove and wash the cup rest and drip tray using mild dish soap.
2. Remove the dispense nozzles and static mixers by rotating each 90° and pulling down. Remove the mixing chambers by pulling straight forward. Wash using mild dish soap.

IMPORTANT: DO NOT wash nozzles, static mixers, or mixing chambers in a dish washer. This will distort the plastic and damage the o-rings. Additionally, do not soak them in sanitizing solution longer than 2 minutes.

Flush once a day for better quality drinks.



WARNING:

Do not leave the unit in FLUSH mode. Leaving the unit in flush mode may result in damage.

WEEKLY

Check concentrate to water brix ratio (refer to the Checking/Adjusting the BRIX Setting).

Sanitize the Juice Dispenser

1. Rinse the unit with hot water.
2. Prepare two 2 oz. (59 ml) packets of Stera-Sheen Green Label sanitizing solution (or similar brand) by dissolving each packet in 1 gallon (3.8L) of potable water to insure 200 ppm of available chlorine.
IMPORTANT: Use potable water at 80°F-100°F (26.7°C-37.8°C). Water above this range breaks down the chlorine count and minimizes sanitation.
3. Remove the juice concentrate containers and place them in separate refrigerated compartment.
4. Flush the system by following the instructions in See “Flush System” on page 15..
5. Fill a clean empty concentrate container with one quart of extremely hot tap water, approximately 140°F (60°C) and place the container into the unit. Dispense all of the hot water into a large container. Repeat for all the remaining dispense valves.
6. Remove the mixing chambers, nozzles, and static mixers. Rinse in hot water to remove excess pulp and concentrate.
7. Place the mixing chambers, nozzles, and static mixers in a separate container of sanitizing solution and agitate vigorously. Allow the parts to soak for two minutes, then rinse thoroughly with fresh tap water.
8. Reinstall the static mixer, nozzles, and mixing chambers

Sanitize Pump System

1. Fill a clean concentrate container with 2 quarts (1.9L) of fresh sanitizing solution.
2. Place Dispense/Flush levers (located on the platform assembly in the refrigerated cabinet) to the **Dispense** position.and close the door.

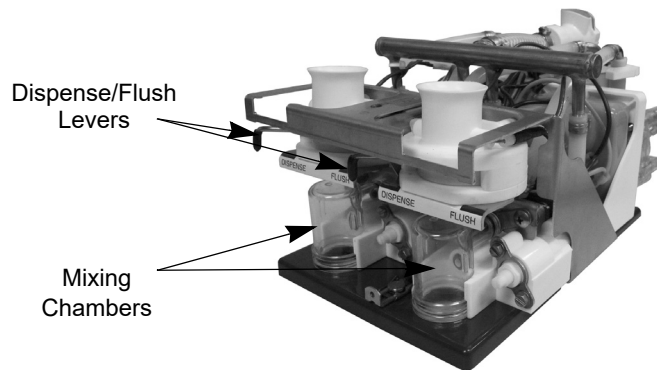

Figure 34. Dispense/Flush Levers

3. Press and hold the dispense button for 90 seconds then release. Allow sanitizing solution to remain in the lines for 5 minutes.



Figure 35. Dispense Buttons

4. After 5 minutes, dispense the remaining sanitizing solution.

Prepare Dispenser for Use

1. Replace sanitizing solution container with a concentrate container and close the door.
2. Press and hold the dispense button until juice appears from the nozzle. Next dispense and discard at least two 8 oz. (236.6ML) cups of juice in order to prime the system and prepare it for operation.

SEMI ANNUALLY

CAUTION:

The following procedures require removal of the dispenser side panel(s). Disconnect the power cord (See Figure 19.) from the receptacle prior to proceeding.



Figure 36. Pull AC Plug from Wall Outlet

Clean Water Inlet Strainer

1. Remove the right side panel from the dispenser.
2. Turn off the water supply to the dispenser.
3. Remove the access port from the “Y” shaped water inlet solenoid located on the right side of the dispenser. (See Figure 20)
4. Clean and reinstall the stainless steel water strainer.



Figure 37. Right Side of Dispenser

Clean Chassis Interior

1. Disconnect power from the dispenser.
2. Remove the top and rear panels; then remove the side panels.
3. Clean the condenser cooling fins
4. Clean the air inlet grilles located on the rear and top panels of the dispenser.
5. Clean the interior base.
6. Wipe the fan blades clean.
7. Reinstall the right side panel, turn on the water supply, and plug the dispenser into the power receptacle.

Check and Top-Off Water Ice Bath

1. Remove the drip tray and lower splash panel.



Figure 38. Drip Tray and Cup Rest

If the Ice bath level is below the **Full** indicator, top it off with water. Refer to the Filling the Ice Bath previously covered in this manual.

ANNUALLY

Replace Pump Tubing and Clean Cabinet

A replacement pump tubing kit, part # 45098, is available. The kit consists of one pre-cut length of pump tubing, two white plastic hose clamps, and instructions. Order two kits for 2-flavor or four kits for 4-flavor units.

Removing Pump Platform(s)

1. Remove the concentrate containers from the dispenser and place them in a refrigerator.
2. Remove the cabinet shelf that the concentrate containers sit on.
3. Flush the system prior to removing the pump platform (refer to the Daily). Remove the dispense nozzles and static mixers.
4. Unplug the water line quick disconnect by pressing the gray button (See Figure 22).

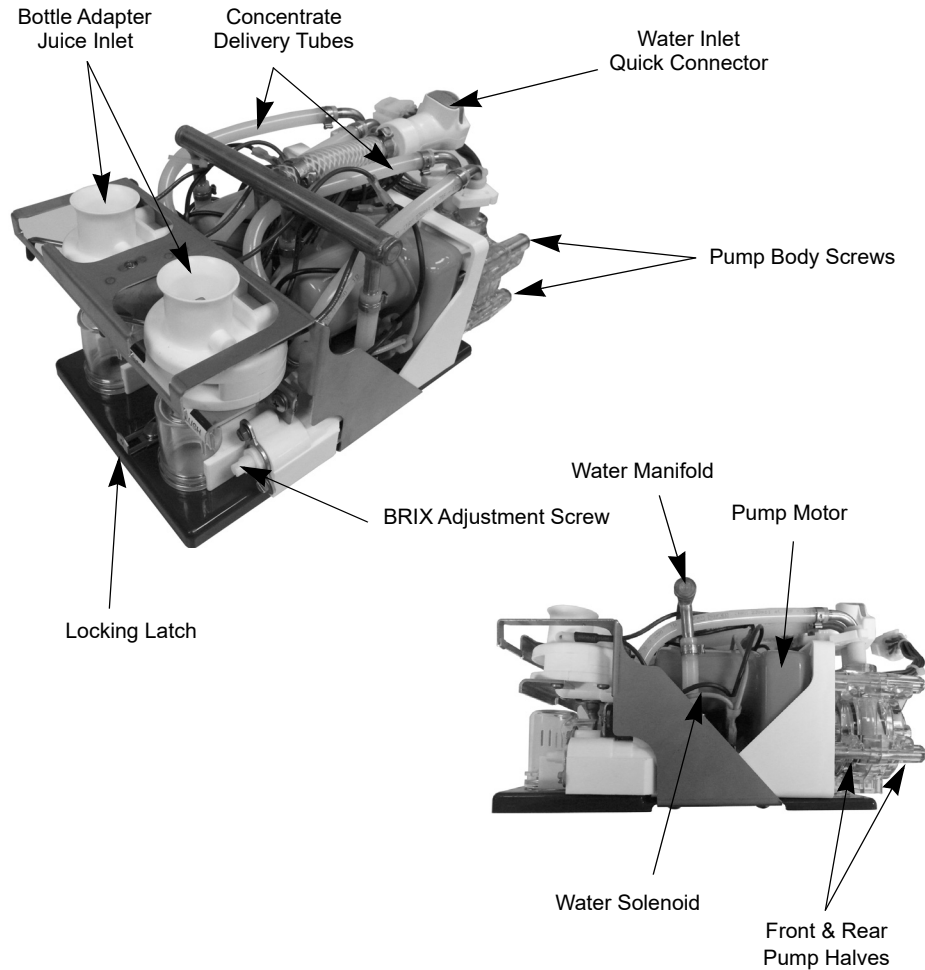

Figure 39. Interior Details

5. Slide the locking latch forward. Lift the platform slightly and pull forward to gain access to the electrical connector (see Figure 22).
6. Unplug the electrical connector by squeezing the locking tabs on either side and pulling out the connector. Lift and remove the pump platform (see Figure 22).

Replacing the Tubing

When the pump platform has been removed, replace the tubing by performing the following procedure.

1. Remove the two white plastic hose clamps from the pump tube connections (See Figure 22) and remove the concentrate delivery tubes from the hose ends.
2. Loosen and remove the four screws from the pump body (See Figure 23).

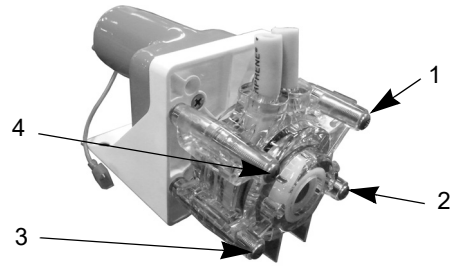

Figure 40. Pump Body Screws

3. Remove **ONLY** the rear pump body half to reveal the pump tubing and rollers (See Figure 24).
4. Remove the old pump tubing from the pump body. If the roller assembly comes out with the tubing, place it back into the pump housing. **Make sure to align the roller assembly shaft keyway to the motor shaft so that the two interlock.**
5. Firmly press the new tubing into the pump body around the roller assembly, making sure to keep the protruding ends even with each other.
6. Once the tubing is in place, hold the tubing with one hand, capture the lower part of the tubing with the outer housing, then proceed to capture the shaft of the roller assembly and push the rear pump housing into place. Make sure to capture the tubing within the body and not pinch it between the halves. Do not use any tool other than your finger tips to manipulate the tubing into the housing or you may damage the tubing.

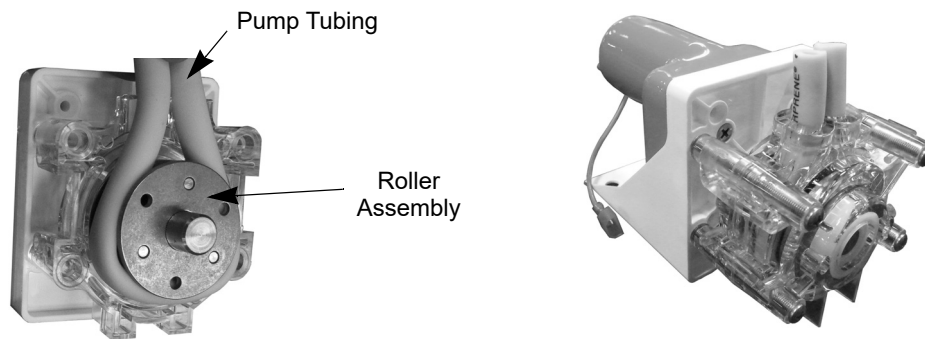

Figure 41. Pump Assembly

7. While holding the pump halves together with your hand, reinsert the four thumb screws (See Figure 23) and tighten using a criss-cross pattern as shown. The thumb screws should be tightened about 1/4 turn beyond snug.
8. Insert the two concentrate delivery tubes into the pump tubing ends and secure them using the new hose clamps supplied in the kit. Be sure to use pliers to squeeze and tighten the hose clamps.

Cleaning the Cabinet

The cabinet bottom surface and walls should be inspected and cleaned annually according to the following steps:

1. Remove natural rubber nozzle bushing gasket (see Figure 17) and inspect it and silicone RTV. If cracked, clean off RTV, and re-apply using kit P/N 729011013 per instructions provided with kit.
2. Re-apply nozzle bushing gasket so that the edges lie flat on the floor of the cabinet.

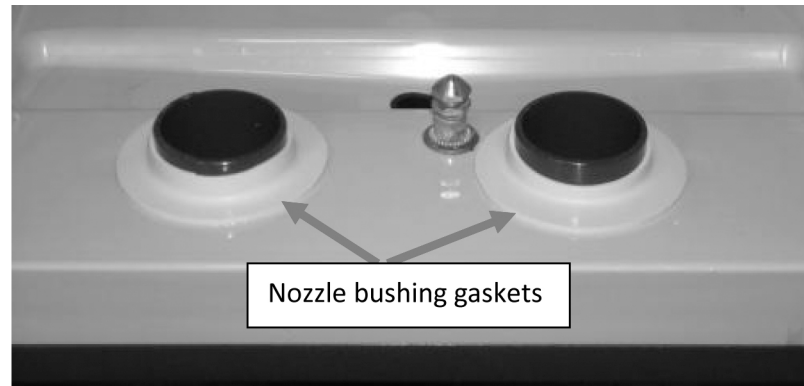

Figure 42. Nozzle bushing gaskets - proper installation

3. Clean cabinet floor and walls of any spilled juice and let dry. Use a mild soap/detergent and plain water.
 4. Reinstall the pump platform in the reverse order given above.
-

Long-term Storage

If the unit is going to be left empty for a long period of time, prepare the unit according to the following steps:

1. Turn off the unit.
2. Allow the water bath to defrost. Once defrosted, empty the water from the water bath.
3. Clean the cabinet and surfaces of the unit.
4. Dry the cabinet and surfaces of the unit.
5. Leave the cabinet door open to prevent mold developing within the cabinet.

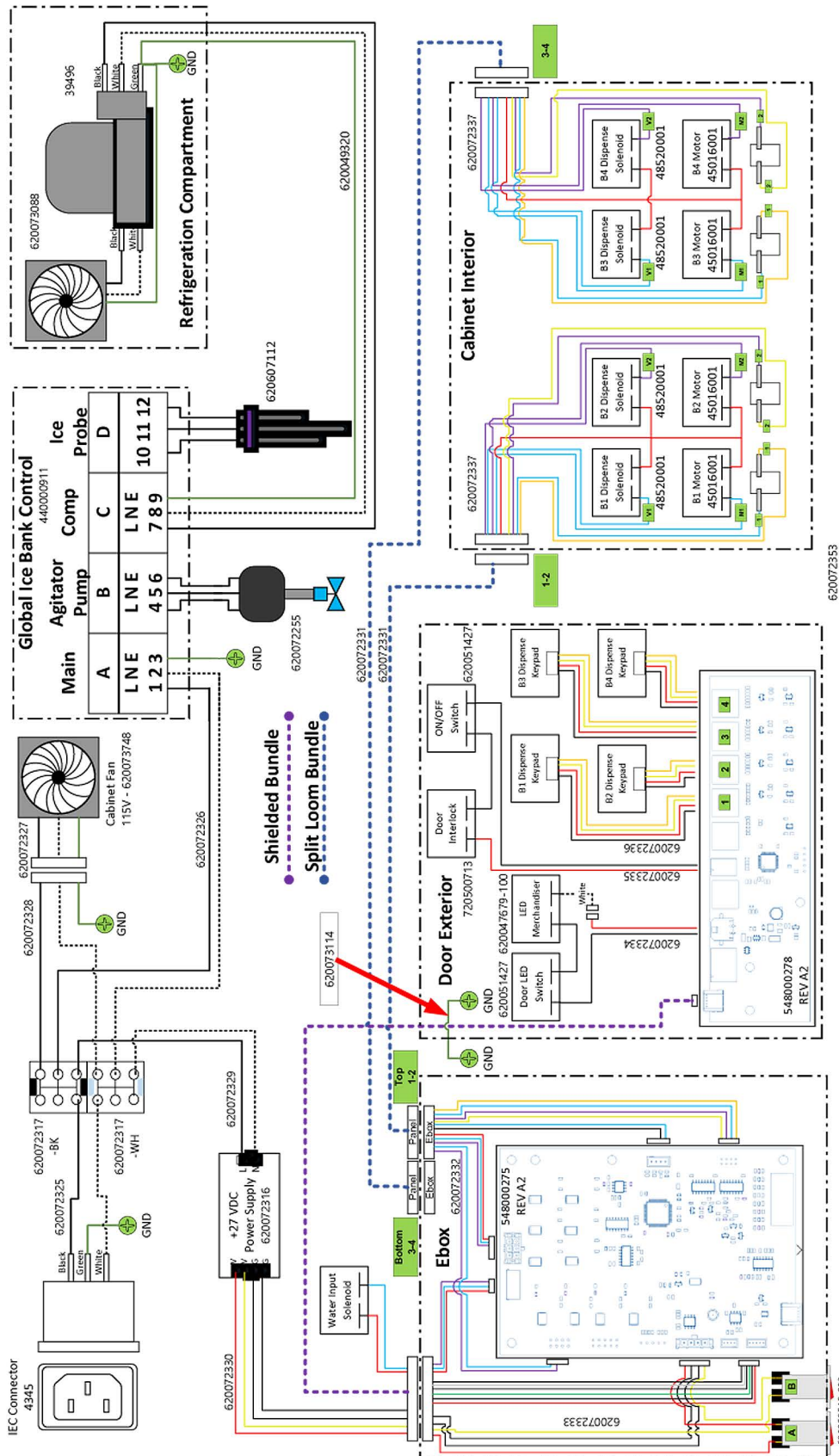

Figure 43. System Wiring Diagram Quest Elite 4FL - 115V

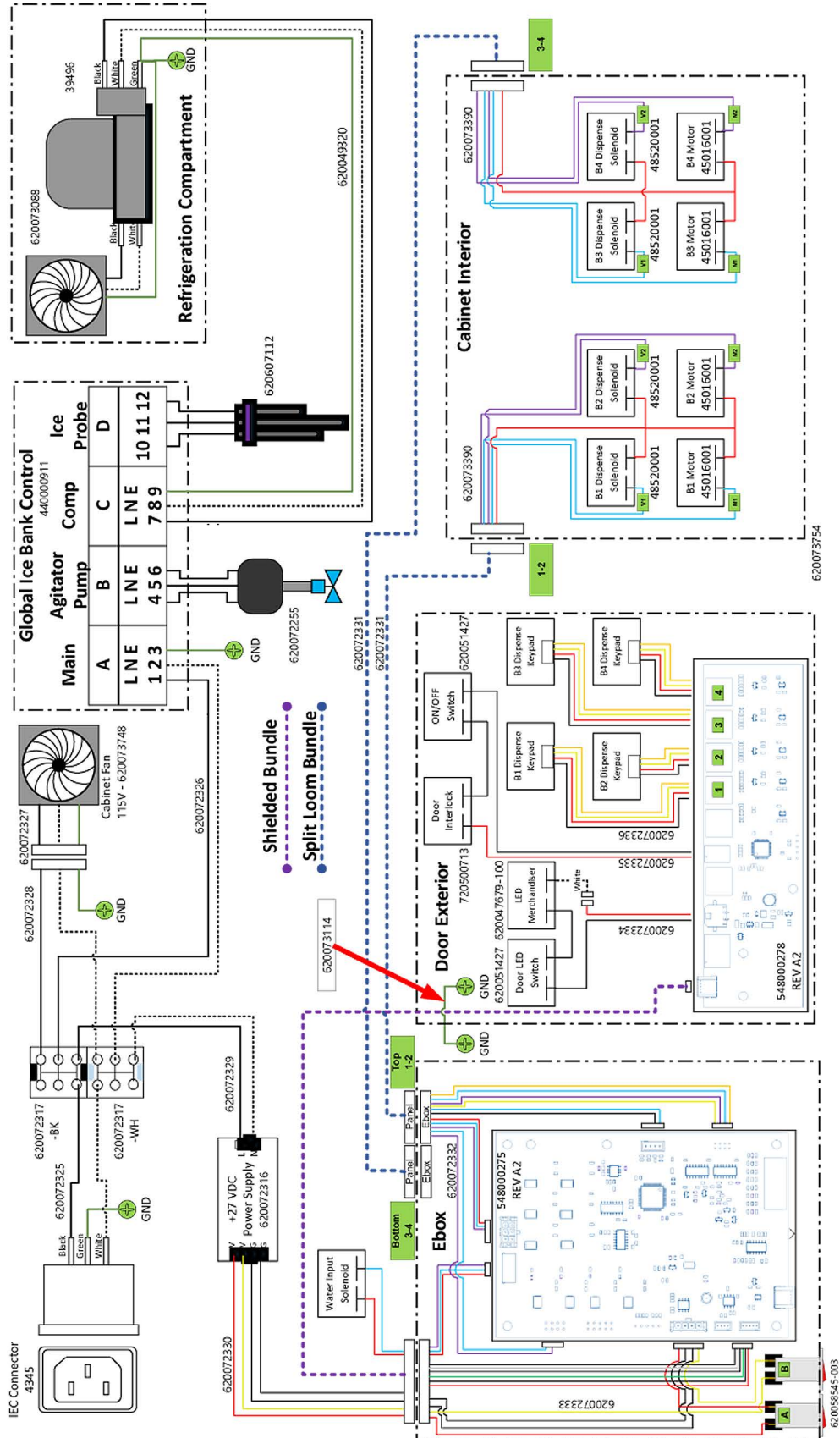

Figure 44. System Wiring Diagram Quest Elite 4FL - 115V - Sold Out/Non Sold Out

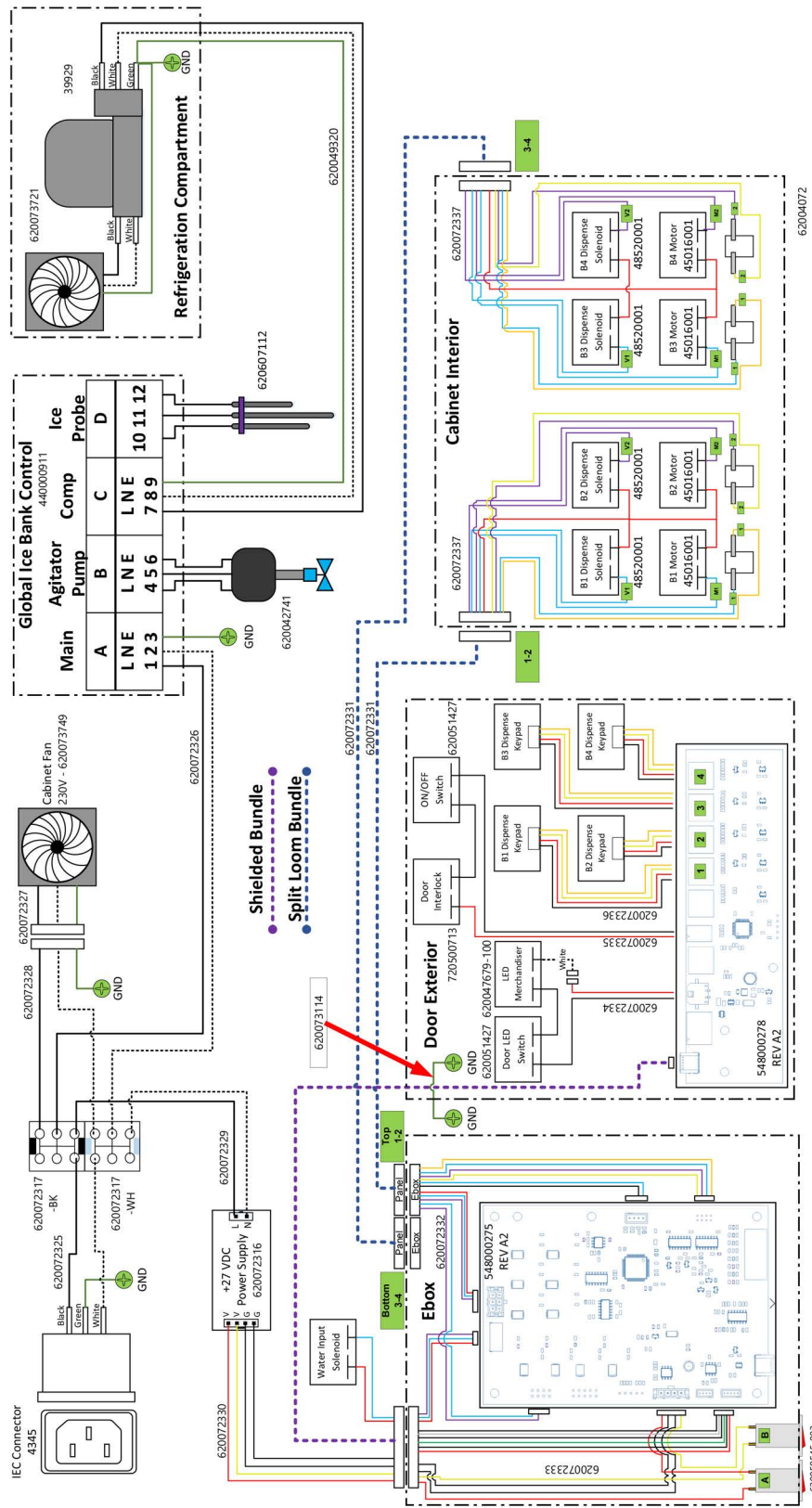

Figure 45. System Wiring Diagram Quest Elite 4FL - 220V

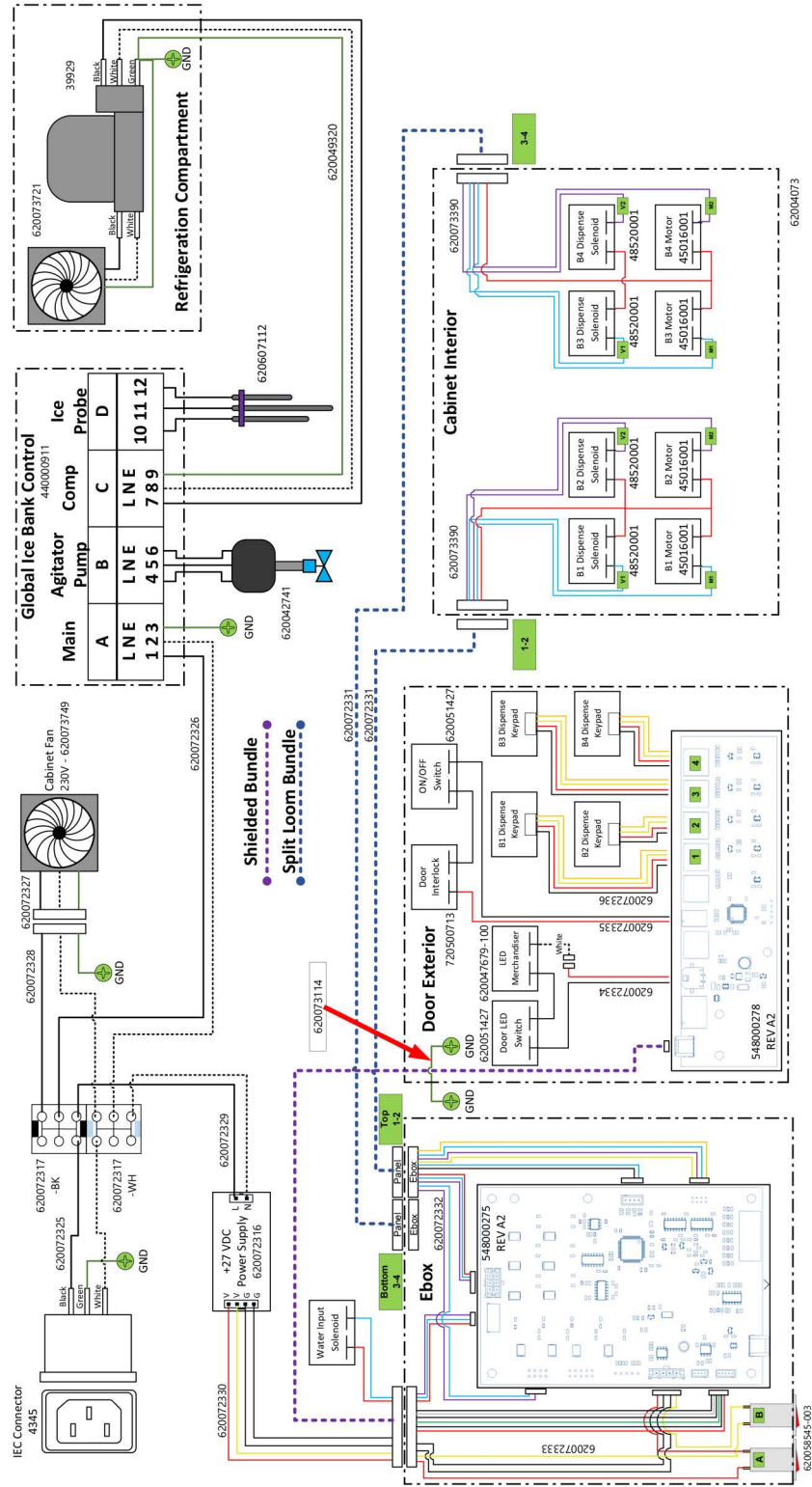
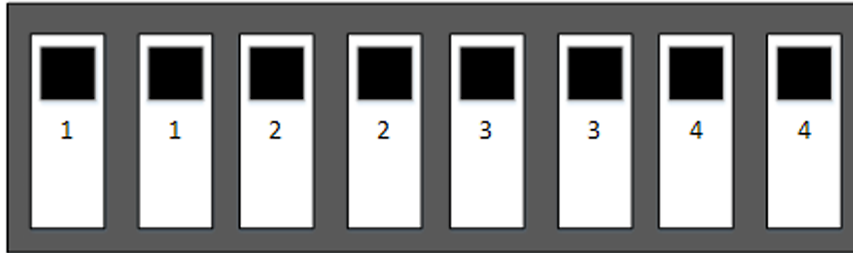

Figure 46. System Wiring Diagram Quest Elite 4FL - 220V - Sold Out/Non Sold Out

Dispenser Motor Speed Control DIP Switch Settings

DIP switch array and associated dispense-motor positions.

Brand/Flavor 1 Brand/Flavor 2 Brand/Flavor 3 Brand/Flavor 4



Definition table of switch positions

DIP Switch Positions	Description
	Lowest Speed
	Medium Low (Eq. Speed Switch LOW)
	Medium High (Eq. Speed Switch High)
	Full Speed

Most commonly used settings

Figure 47. Motor Speed Selection DIP Switch Guide



TROUBLESHOOTING GUIDE

The following tables contain trouble-shooting information intended to aid an experienced service person in diagnosing operational problems that may occur. For further assistance, contact the Cornelius Customer Services department at 800-283-3600 between the hours of 7:30A.M. and 5:00P.M. Central Standard Time. You must have the model and serial number (Located on the right side of the dispenser) when calling.

Table 4

Symptom	Probable Cause	Remedy
Unit totally inoperative	<ul style="list-style-type: none"> A. No power to dispenser due to tripped circuit breaker. B. Loose or broken power supply connection inside dispenser. 	<ul style="list-style-type: none"> A. Reset circuit breaker. Confirm that breaker is correct size & no other equipment is operating on the same circuit. Also confirm that supply voltage is +/-10% of nameplate specification. B. Repair connection.
No Cooling	<ul style="list-style-type: none"> A. Line voltage not within nameplate specification causing compressor overload to trip. B. No water in water ice bath or water level extremely low, exposing ice bank sensing probe. C. Defective Ice Bank Control or sensing probe. D. Cabinet fan inoperative resulting in warm concentrate (water continues to cool). E. Compressor short cycles on overload. F. Compressor starts but hums & trips overload. G. Defective compressor overload or start capacitor. H. Compressor starts but does not switch off of start winding. I. Refrigerant leak. 	<ul style="list-style-type: none"> A. Contact an electrician. B. Fill ice bath to proper water level. C. Replace. D. Replace. E. Excessively high discharge pressure due to restricted condenser or inoperative condenser fan motor. F. Seized or shorted compressor, replace. G. Test & replace. H. Relay or compressor is defective. Test & replace faulty item. I. Repair leak, evacuate & recharge system.
No water dispensed, concentrate only	<ul style="list-style-type: none"> A. No water in dispenser. B. Water supply line inside refrigerated cabinet disconnected from pump platform. C. Water solenoid located on pump platform clogged or defective. D. Main water solenoid/strainer located at the rear of dispenser is clogged, binding or defective. E. Water supply pressure is greater than 80 psi (5.5 bar) forcing BRIX flow control closed. F. Freeze-up of water coil in ice bath. 	<ul style="list-style-type: none"> A. Restore water. B. Reconnect C. Disassemble & clean solenoid. Replace if necessary. D. Remove & clean strainer. Confirm 24VDC is present at solenoid during dispense. Confirm solenoid coil is not open. Disassemble & clean solenoid. E. Add external regulator & lower pressure to 50 psi (3.5 bar). F. Unplug dispenser & allow 2-4 hrs. to thaw. Check operation of agitator motor & ice bank control. Refrigeration system may be low on charge resulting in a deformed ice bank & freeze-up of water coil in ice bath.



Table 4

Symptom	Probable Cause	Remedy
No water & no concentrate, refrigeration is working.	<ul style="list-style-type: none"> A. Black service switch located on the rear of the cabinet door in OFF position. B. White door switch open C. 6.25 amp fuse inside front electrical box blown. D. No output from transformer. E. Defective voltage regulator board (VRB) located inside front electrical box. F. Defective dispense push button or portion control board. 	<ul style="list-style-type: none"> A. Turn on switch. B. Door switch must be closed in order to dispense. Check switch operation & replace if necessary. C. Replace with 6.25, 250VAC slow blow fuse & test. D. Confirm transformer output of 24VAC +/- 2. Replace transformer if necessary. E. Measure across the VDC output of the board. There should be 28VDC present when the dispense button is pressed. Replace VRB if necessary. F. Test & replace if necessary.
No concentrate dispensed, water only.	<ul style="list-style-type: none"> A. Concentrate container not fully engaged into receptacle on pump platform. B. Dispense/Flush lever in FLUSH position C. Concentrate too cold, not properly thawed. D. Defective pump motor. 	<ul style="list-style-type: none"> A. Refer to Concentrate Loading section of this manual. B. Move lever to DISPENSE position C. Concentrate should be 35 to 40°F (1.7 to 4.5°C) prior to loading. D. Replace pump motor.
Warm drinks	<ul style="list-style-type: none"> A. Ambient air around dispenser is too warm. B. Excessive demand on dispenser. C. Dirty condenser coil. D. Inoperative condenser fan. E. Defective Ice Bank Control. F. Loss of refrigerant charge due to leak in system. G. Water bath low on water. 	<ul style="list-style-type: none"> A. Relocate dispenser. B. Add water pre-cooler or second dispenser C. Clean condenser coil. D. Replace condenser fan motor. E. Test & replace if necessary. F. Repair leak and recharge system. G. Top off water bath.
Water continuously drips from nozzle in OFF mode.	<ul style="list-style-type: none"> A. Main water solenoid at base of unit or water solenoid on pump platform not shutting off completely. 	<ul style="list-style-type: none"> A. Clean solenoid(s), replace parts as necessary (refer to Planned Maintenance section).
Concentrate warm, water cold.	<ul style="list-style-type: none"> A. Cabinet fan inoperable. B. Agitator motor/pump inoperable or restricted. C. Loss of refrigerant charge due to leak in system. 	<ul style="list-style-type: none"> A. Check/replace fan. B. Check/replace agitator motor. C. Repair leak & recharge system.
BRIX problem	<ul style="list-style-type: none"> A. Water supply pressure too low, less than 20 psi (1.4 bar) flowing water pressure. B. Water flow control binding or spring is defective. C. Improperly thawed concentrate. BRIX changes as concentrate temperature changes (concentrate becomes thinner as temperature rises) 	<ul style="list-style-type: none"> A. Correct water supply problem to ensure a constant 50 psi (3.5 bar) flowing to dispenser. B. Clean and/or replace parts as necessary. C. Concentrate should be 35 to 40°F (1.7 to 4.5°C) prior to loading.



Table 4

Symptom	Probable Cause	Remedy
Pump inoperative	A. Pump motor defective. B. No power to transformer or no 24VAC output from transformer. C. Defective voltage regulator board (VRB) located inside front electrical box. D. Defective dispense control board (Push button or portion control).	A. 28VDC should be present at pump motor during dispense. If voltage is present & motor does not start, replace motor. B. Confirm transformer has line voltage present on primary side. If no 24VAC output from secondary, replace transformer. C. Confirm board produces 28VDC present when dispense button is pressed (refer to Electrical Box Wiring Diagram for VDC output location). Replace VRB if necessary. D. Test & replace if necessary.
Machine continues to dispense after dispense button is released or dispenses without operator input.	A. Push button or portion control pad stuck in ON position. B. Relay on voltage regulator board (VRB) stuck on.	A. Disconnect wire harness from rear of portion control and close the door. If unit does not dispense on its own, dispense control board is bad (stuck on). B. Disconnect 4-wire harness from lower right corner of VRB. If unit continues to dispense on its own VRB is defective (relay stuck on).



CORNELIUS STANDARD SERVICE CALL GUIDE

The parts warranty referenced in the Certificate of Warranty in this manual applies to the replacement of the defective part. Cornelius Inc. will not accept parts warranty claims for water leaks applicable to the installation, clogged drains, adjustments of any kind including regulators, pumps, thermostats, ratio, or brix settings, stratification issues, preventative maintenance, sanitizing, etc. Cornelius Inc. will consider only actual service time on the equipment. Charges for mileage, holiday pay, night charges, and overtime will not be considered. All parts claim that are fare, reasonable, and within the terms of the warranty and allotted repair times will be paid in U.S. Dollars.

Any questions regarding the warranty procedures can be directed to our Customer Services group at 800-238-3600.

ITEM #	PAGE #	DESCRIPTION	MAX HOURS

*Recovery and pump down require at least two hours depending on contamination and is not included in the allotted repair time shown above.



QUEST ELITE 4FL DECOMMISSIONING PROCEDURES



[BLANK]

DECOMMISSIONING PROCESS

Before carrying out this procedure, it is essential that the technician is completely familiar with the equipment and all its detail. It is recommended good practice that all refrigerants are recovered safely. Prior to the task being carried out, an oil and refrigerant sample shall be taken in case analysis is required prior to re-use of recovered refrigerant. **It is essential that electrical power is available for recovery-equipment use before the procedure is commenced.**

Decommissioning Procedure

- 1) Become familiar with the equipment and its operation.
- 2) Isolate the system electrically by disconnecting all AC power sources.
- 3) Before beginning the procedure, ensure that:
 - Mechanical handling equipment is available, if required, for handling refrigerant cylinders;
 - All personal protective equipment is available and being used correctly;
 - The recovery process is supervised at all times by a competent person;
 - Recovery equipment and cylinders conform to the appropriate standards.
- 4) Pump down the refrigerant system, if possible. NOTE: If a vacuum is not possible, make a manifold so that refrigerant can be removed from various parts of the system.



CAUTION:

Do not overfill cylinders (no more than 80% volume liquid charge).

Do not exceed the maximum working pressure of the cylinder, even temporarily.



CAUTION:

When the cylinders have been filled correctly and the process completed, make sure that the cylinders and the equipment are removed from site promptly and all isolation valves on the equipment are closed off.



CAUTION:

Recovered refrigerant shall not be charged into another REFRIGERATING SYSTEM unless it has been cleaned and checked.



CAUTION:

DO NOT switch recovery system on/off near the source of flammable refrigerant that may be leaking out or may leak out during recovery-system line connection/disconnection.

Recovery Requirements and Guidelines

When removing refrigerant from a system, either for servicing or decommissioning, it is recommended good practice that all refrigerants are removed safely.

When transferring refrigerant into cylinders, ensure that only appropriate refrigerant recovery cylinders are employed. Ensure that the correct number of cylinders for holding the total system charge is available. All cylinders to be used are designated for the recovered refrigerant and labeled for that refrigerant (i.e. special cylinders for the recovery of refrigerant). Cylinders shall be complete with pressure-relief valve and associated shut-off valves in good working order. Empty recovery cylinders are evacuated and, if possible, cooled before recovery occurs.

The recovery equipment shall be in good working order with a set of instructions concerning the equipment that is at hand and shall be suitable for the recovery of all appropriate refrigerants including, when applicable, FLAMMABLE REFRIGERANTS. In addition, a set of calibrated weighing scales shall be available and in good working order. Hoses shall be complete with leak-free disconnect couplings and in good condition. Before using the recovery machine, check that it is in satisfactory working order, has been properly maintained and that any associated electrical components are sealed to prevent ignition in the event of a refrigerant release. Consult manufacturer if in doubt.

The recovered refrigerant shall be returned to the refrigerant supplier in the correct recovery cylinder, and the relevant waste transfer note arranged. Do not mix refrigerants in recovery units and especially not in cylinders.



NOTE: For appliances containing flammable refrigerants, refrigerant purging shall be achieved by breaking vacuum in the system with oxygen-free nitrogen and continuing to fill until the working pressure is achieved; then venting to atmosphere, and finally pulling down to a vacuum. This process shall be repeated until no refrigerant is within the system. When the final oxygen-free nitrogen charge is used, the system shall be vented down to atmospheric pressure to enable work to take place.

If compressors or compressor oils are to be removed, ensure that they have been evacuated to an acceptable level to make certain that FLAMMABLE REFRIGERANT does not remain within the lubricant. The evacuation process shall be carried out prior to returning the compressor to the suppliers. Only electric heating to the compressor body shall be employed to accelerate this process. When oil is drained from a system, it shall be carried out safely.

Competence of service personnel Information of procedures additional to usual information for refrigerating appliance installation, repair, maintenance and decommission procedures is required when an appliance with FLAMMABLE REFRIGERANTS is affected. The training of these procedures is carried out by national training organizations or manufacturers that are accredited to teach the relevant national competency standards that may be set in legislation. The achieved competence should be documented by a certificate.

5) Label the equipment as indicated below:

Labeling

Equipment shall be labeled stating that it has been de-commissioned and emptied of refrigerant. The label shall be dated and signed. For appliances containing FLAMMABLE REFRIGERANTS, ensure that there are labels on the equipment stating the equipment contains FLAMMABLE REFRIGERANT.

Decommissioning

If safety is affected when the equipment is taken out of service, the REFRIGERANT CHARGE shall be removed before decommissioning.

Ensure sufficient ventilation at the equipment location.

Be aware that malfunction of the equipment may be caused by refrigerant loss and a refrigerant leak is possible.

Discharge capacitors in a way that won't cause any spark, using a Supco CapDis tool.

Remove the refrigerant. If recovery is not required by national regulations, drain the refrigerant to the outside. Take care that the drained refrigerant will not cause any danger. In doubt, one person should guard the outlet. Take special care that drained refrigerant will not float back into the building.

When FLAMMABLE REFRIGERANTS are used:

- A) Evacuate the refrigerant circuit.
- B) Purge the refrigerant circuit with oxygen-free nitrogen for 5 min.
- C) Evacuate again.
- D) Fill with nitrogen up to atmospheric pressure.
- E) Put a label on the equipment that the refrigerant is removed.

Information On Correct Working Procedures

Commissioning

Ensure that floor area is sufficient for REFRIGERANT CHARGE or that the ventilation duct is assembled in a correct manner.

Connect pipes and carry out a leak test before charging with refrigerant.

Check safety equipment before putting into service.

Maintenance

Portable equipment shall be repaired outside or in a workshop specially equipped for servicing units with FLAMMABLE REFRIGERANTS.

Ensure sufficient ventilation at repair place.



Be aware that malfunction of the equipment may be caused by refrigerant loss and a refrigerant leak is possible.

Discharge capacitors in a way that won't cause any spark, using a Supco CapDis tool. (The standard procedure to short circuit the capacitor terminals usually creates sparks.)

Reassemble sealed enclosures accurately. If seals are worn, replace them.

Check safety equipment before putting into service.

Repair

Portable equipment shall be repaired outside or in a workshop specially equipped for servicing units with FLAMMABLE REFRIGERANTS.

Ensure sufficient ventilation at the repair place.

Be aware that malfunction of the equipment may be caused by refrigerant loss and a refrigerant leak is possible.

Discharge capacitors in a way that won't cause any spark, using a Supco CapDis tool.

When BRAZING is required, the following procedures shall be carried out in the order indicated:

- A) Remove the refrigerant. If the recovery is not required by national regulations, drain the refrigerant to the outside. Take care that the drained refrigerant will not cause any danger. In doubt, one person should guard the outlet. Take special care that drained refrigerant will not float back into the building.
- B) Evacuate the refrigerant circuit.
- C) Purge the refrigerant circuit with oxygen-free nitrogen for 5 min. (not required for A2L refrigerants)
- D) Evacuate again (not required for A2L REFRIGERANTS).
- E) Remove parts to be replaced by cutting, not by flame.
- F) Purge the braze point with nitrogen during the brazing procedure at the pressure indicated below.
- G) Carry out a leak test before charging with refrigerant at the pressure indicated below.

Models	Low Side Pressure (psig)	High Side Pressure (psig)
QST Elite 4FL	88	282

NOTES:

Reassemble sealed enclosures accurately. If seals are worn, replace them.

Check safety equipment before putting into service.

When BRAZING is required, the following procedures shall be carried out in the following order:

Ensure sufficient ventilation in the work area.

- A) Make sure the power to the unit is turned Off.
- B) Safely remove the refrigerant following local and national regulations. If the recovery is not required by national regulations, drain the refrigerant to the outside. Take care that the drained refrigerant will not cause any danger. In doubt, one person should guard the outlet. Take special care that drained refrigerant will not float back into the building.
- C) Purge the refrigerant circuit with oxygen free nitrogen.
- D) Evacuate the refrigerant circuit.
- E) Purge the refrigerant circuit with oxygen-free nitrogen for 5 min.
- F) Evacuate again.
- G) Remove parts to be replaced by cutting or brazing.
- H) Purge the braze point with nitrogen during the brazing procedure required for repair.
- I) Carry out a leak test before charging with refrigerant.



When FLAMMABLE REFRIGERANTS are used:

- A) Evacuate the refrigerant circuit.
- B) Purge the refrigerant circuit with oxygen free nitrogen.
- C) Evacuate again.
- D) Cut out the compressor and drain the oil.

Disposal

Ensure sufficient ventilation in the work area.

Remove the refrigerant.

Where controlled, refrigerant-recovery is required, follow all local regulatory guidelines and requirements.

Where refrigerant recovery is not required by local/national regulations, drain the refrigerant to the outside. Take care that the drained refrigerant will not cause any danger. A designated person should oversee this process to ensure safety. Take special care that drained refrigerant will not drift back into the building during the draining process.

When FLAMMABLE REFRIGERANTS are used:

- A) Evacuate the refrigerant circuit.
- B) Purge the refrigerant circuit with oxygen-free nitrogen for 5 min.
- C) Evacuate again.
- D) Cut out the compressor and drain the oil.

