

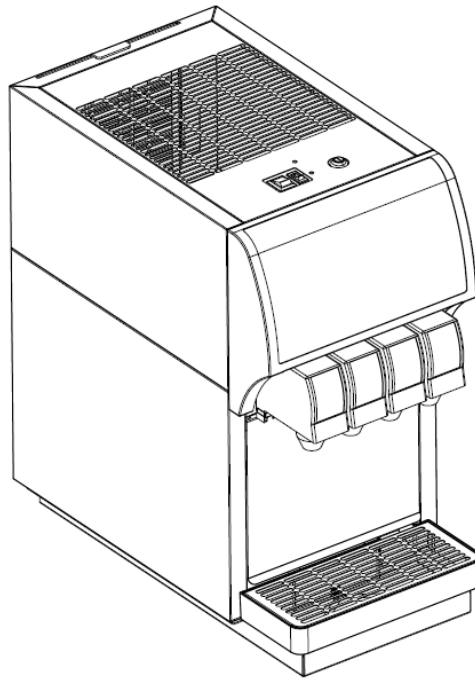

Titan_4HC

POST-MIX BEVERAGE DISPENSER

Installation, Operation & Service Manual



Publication Number: 890569406

Revision Date: 2022.9.30

Revision: 1.2

Visit the Cornelius web site at www.cornelius.com for all your Literature needs.

NOTICE:

The products, technical information, and instructions contained in this manual are subject to change without notice. These instructions are not intended to cover all details or variations of the equipment, nor to provide for every possible contingency in the installation, operation or maintenance of this equipment. This manual assumes that the person(s) working on the equipment have been trained and are skilled in working with electrical, plumbing, pneumatic, and mechanical equipment. It is assumed that appropriate safety precautions are taken and that all local safety and construction requirements are being met, in addition to the information contained in this manual.

This Product is warranted only as provided in Cornelius' Commercial Warranty applicable to this Product and is subject to all of the restrictions and limitations contained in the Commercial Warranty.

Cornelius will not be responsible for any repair, replacement or other service required by or loss or damage resulting from any of the following occurrences, including but not limited to, (1) other than normal and proper use and normal service conditions with respect to the Product, (2) improper voltage, (3) inadequate wiring, (4) abuse, (5) accident, (6) alteration, (7) misuse, (8) neglect, (9) unauthorized repair or the failure to utilize suitably qualified and trained persons to perform service and/or repair of the Product, (10) improper cleaning, (11) failure to follow installation, operating, cleaning or maintenance instructions, (12) use of "non-authorized" parts (i.e., parts that are not 100% compatible with the Product) which use voids the entire warranty, (13) Product parts in contact with water or the product dispensed which are adversely impacted by changes in liquid scale or chemical composition.

Contact Information:

To inquire about current revisions of this and other documentation or for assistance with any Cornelius product contact:

www.cornelius.com

+86-22-2529-0858

Trademarks and Copyrights:

This document contains proprietary information and it may not be reproduced in any way without permission from Cornelius.

This document contains the original instructions for the unit described.

CORNELIUS INC

12 Xin Tai Road, TEDA,

Tianjin, PRC300457

Correct Disposal of this Product

This marking indicates that this product should not be disposed with other household wastes throughout the EU. To prevent possible harm to the environment or human health from uncontrolled waste disposal, recycle it responsibly to promote the sustainable reuse of material resources. To return your used device, please use the return and collection systems or contact the retailer where the product was purchased. They can take this product for environmental safe recycling



TABLE OF CONTENTS

SAFETY INSTRUCTIONS	1
Read and Follow ALL Safety Instructions	1
Safety Overview.....	1
Recognition.....	1
Different Types of Alerts	1
Safety Tips	1
Qualified Service Personnel.....	2
Safety Precautions	2
Shipping And Storage.....	2
CO2 (Carbon Dioxide) Warning	2
Power Cord	2
Sound Level	3
Unit Location	3
GENERAL INSTRUCTIONS	3
GENERAL DESCRIPTION.....	3
WARRANTY REFERENCE INFORMATION	3
UNIT DESCRIPTION.....	3
Unit Specification.....	4
CAPACITY	4
Miscellaneous Information	5
Theory of Operation.....	5
INSTALLATION	7
Delivery Inspection and Unpacking.....	7
Dimensions.....	7
Installation Requirements	8
Electrical Requirements.....	8
AMBIENT TEMPERATURE REQUIREMENTS	8
Installation Procedure.....	9
Counter-top Installation.....	9
Connect Syrup, Water and Carbonated Water Lines.....	11
Primary and Secondary CO2 Regulator Settings	11
Connect Electrical Power.....	12
Check for Leaks.....	12
Reinstall Panels	12
Adjust Water-To-Syrup Ratio	12
Adjusting Flow Rates	13



OPERATIO	14
Instructions	14
Dispensing Product	14
Replenishing Syrup Supply.....	14
Tank System.....	14
Bag-In-Box System	14
Adjustments	14
Water-to-Syrup Ratio Adjustment	14
Cleaning and Checks	15
Daily Cleaning	15
Daily Checks	15
Sanitizing Syrup Systems.....	15
Sanitizing Syrup Tank Systems	15
Sanitizing Bag-In-Box Syrup System	16
Condenser Cleaning.....	16
Clean Air Filter.....	16
Sanitizing by Diversol CX	16
SERVICE	18
Preventative Maintenance	18
Preventative Maintenance Summary	18
Sanitizing.....	18
Double Liquid Check Valve Inspection & Cleaning	18
Check for Leaks	18
Check Ratio.....	18
Clean Condenser.....	18
Clean BIB Connectors	18
Clean Air Filter.....	19
Adjustments	19
CO2 Connection.....	19
Primary and Secondary CO2 Regulator Settings.....	19
COMPONENT SERVICE.....	21
Carbonator Pump Replacement	21
Pump Motor Replacement.....	21
Agitator Motor Replacement.....	21
Condenser Fan Motor Replacement.....	21
TROUBLE SHOOTING	23
REFERENCE MATERIAL	26
Wiring Diagram	26
Plumbing Diagram.....	27

SAFETY INSTRUCTIONS

READ AND FOLLOW ALL SAFETY INSTRUCTIONS

Safety Overview

- Read and follow **ALL SAFETY INSTRUCTIONS** in this manual and any warning/caution labels on the unit (decals, labels or laminated cards).
- Read and understand ALL applicable OSHA (Occupational Safety and Health Administration) safety regulations before operating this unit.
- **Must wear gloves when the technicians start to service or maintain.**

Recognition

<i>Recognize Safety Alerts</i>
 <p><i>This is the safety alert symbol. When you see it in this manual or on the unit, be alert to the potential of personal injury or damage to the</i></p>

DIFFERENT TYPES OF ALERTS

DANGER:

Indicates an immediate hazardous situation which if not avoided **WILL** result in serious injury, death or equipment damage.

WARNING:

Indicates a potentially hazardous situation which, if not avoided, **COULD** result in serious injury, death, or equipment damage.

CAUTION:

Indicates a potentially hazardous situation which, if not avoided, **MAY** result in minor or moderate injury or equipment damage.

SAFETY TIPS

- Carefully read and follow all safety messages in this manual and safety signs on the unit.
- Keep safety signs in good condition and replace missing or damaged items.
- Learn how to operate the unit and how to use the controls properly.
- This appliance can be used by children aged from 8 years and above and persons with reduced physical, sensory or mental capabilities or lack of experience and knowledge if they have been given supervision or instruction concerning use of the appliance in a safe way and understand the hazards involved. Children shall not play with the appliance. Cleaning and user maintenance shall not be made by children without supervision.
- Keep your unit in proper working condition and do not allow unauthorized modifications to the unit.



QUALIFIED SERVICE PERSONNEL

⚠ WARNING:

Only trained and certified electrical, plumbing and refrigeration technicians should service this unit. **ALL WIRING AND PLUMBING MUST CONFORM TO NATIONAL AND LOCAL CODES. FAILURE TO COMPLY COULD RESULT IN SERIOUS INJURY, DEATH OR EQUIPMENT DAMAGE.**



WARNING: The Flammable refrigerant is used in the system.
Do not tamper with it. Contact qualified service personal before disposal.

SAFETY PRECAUTIONS

This unit has been specifically designed to provide protection against personal injury. To ensure continued protection observe the following:

⚠ WARNING:

Disconnect power to the unit before servicing following all lock out/tag out procedures established by the user. Verify all of the power is off to the unit before any work is performed.

Failure to disconnect the power could result in serious injury, death or equipment damage.

⚠ CAUTION:

Always be sure to keep area around the unit clean and free of clutter. Failure to keep this area clean may result in injury or equipment damage.

SHIPPING AND STORAGE

⚠ CAUTION:

Before shipping, storing, or relocating the unit, the unit must be sanitized and all sanitizing solution must be drained from the system. A freezing ambient environment will cause residual sanitizing solution or water remaining inside the unit to freeze resulting in damage to internal components.

CO₂ (CARBON DIOXIDE) WARNING

⚠ DANGER:

CO₂ displaces oxygen. Strict attention **MUST** be observed in the prevention of CO₂ gas leaks in the entire CO₂ and soft drink system. If a CO₂ gas leak is suspected, particularly in a small area, **IMMEDIATELY** ventilate the contaminated area before attempting to repair the leak. Personnel exposed to high concentrations of CO₂ gas experience tremors which are followed rapidly by loss of consciousness and **DEATH**.

POWER CORD

If the power cord is damaged, it must be replaced by a special cord available from the manufacturer or its service agent. Detachable cord sets should meet the below requirements:

- Cord type should be H05VV-F or stronger, with earthing conductor;
- Cord section should be minimum nominal cross-sectional area of 1.0mm²;
- Plug should also be earthing type and obtain approval with above cord.



SOUND LEVEL

The A-weighted sound pressure level has been determined to be below 70dBA.

UNIT LOCATION

This unit is not designed for use in outdoor locations.



CAUTION:

Appliance is not suitable for installation in an area where a water jet could be used.



CAUTION:

The Appliance must be placed vertically on horizontal Surface.

GENERAL INSTRUCTIONS

GENERAL DESCRIPTION

This manual is a guide for installing, operating, and maintaining this equipment. This section gives the Unit Description, theory of Operation, and design data for Post-Mix Beverage Over Counter Dispenser. This unit must be installed and serviced by a qualified service person. This unit contains no user serviceable parts.

WARRANTY REFERENCE INFORMATION

Warranty Registration Date (to be filled out by customer)	
Unit Part Number:	
Serial Number:	
Install Date:	
Local Authorized Serviced Center:	

UNIT DESCRIPTION

The unit over the counter, post-mix, beverage dispenser is compact, lightweight, and can be ordered with or without a built-in carbonator. Syrup pump kits are available for the units.

The units may be island mounted or installed on a front or rear counter. The 1/4 H.P. refrigeration deck is easily removed for service and maintenance. Adjustable water flow regulators and syrup flow regulators, located on dispensing valves, are easily accessible.

Features:

- Key-lock switch
- Lighted merchandiser
- Syrup pump kit (optional)
- Removable drip tray
- Circuit breaker
- Built-in carbonator
- Removable refrigeration deck (s)

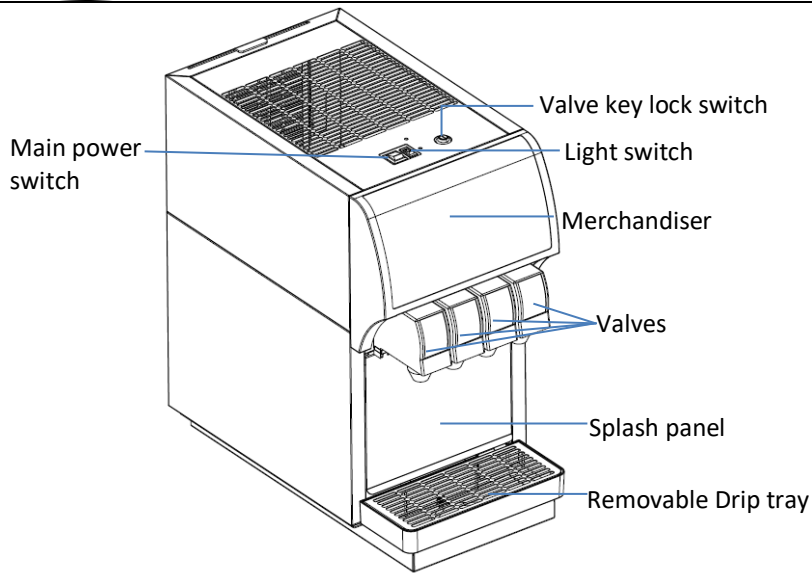

Figure 1

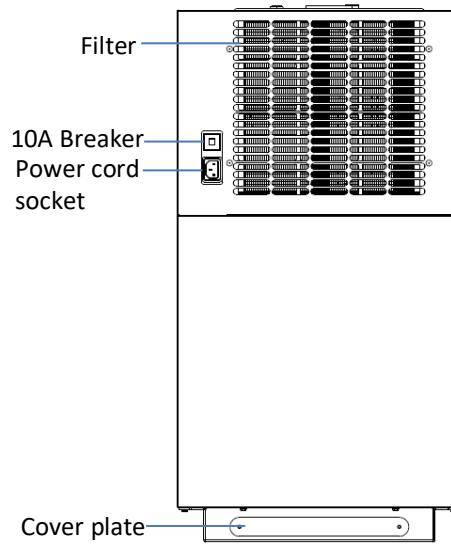

Figure 2

UNIT SPECIFICATION

Height	27.8 inches (max)	705mm
Width	14.7 inches	374mm
Depth	26.0 inches	661mm
Shipping weight(approx)	154lb	70Kg
Water Bath Size	9.5 gal (US)	36L
Ice Bank Weight	16.5lb	7.5Kg

Note: Rated power supply please refer to the nameplate.

CAPACITY

Assuming:

- 1.5~3 oz/sec. dispensing rate
- 90° F (32.2° C) ambient temperature
- Two 12-oz. drinks per minute
- Drink temperature <40°F (4.4°C) for CSD and <42°F (5.5°C) for NCB

Draw Capacity:

60 cups at 12OZ/2 cups per minute at 90° F (32.2° C) ambient



Miscellaneous Information

Refrigerant.....R290
Compressor HP.....1/4HP
Design Valve Flow Rate..... 1.5~3.0 oz./sec
Standard Valve.....LEV, SFV...
Cup Clearance.....256 mm (10 inches)
Sanitary Approvals.....NSF 18
Electronic Controls.....Electronic ice bank and liquid level control

THEORY OF OPERATION

Note: The equipment has a basic factory configuration according to the customer's requirements.

1. All carbonate model.
2. All non-carbonated models.
3. CSD and NCB interchangeable models.

A CO₂ cylinder delivers carbon dioxide (CO₂) gas through adjustable CO₂ regulators to the applicable syrup tanks or bag-in-box syrup pumps and also the integral (built-in) carbonator. Plain water enters the integral carbonator carbonated water tank and is carbonated by CO₂ gas pressure also entering the water tank. When dispensing valve is activated, CO₂ gas pressure exerted upon the applicable syrup tank contents or bag-in-box syrup pump pushes syrup from the syrup supply, through the Unit syrup cooling coil, and on to the dispensing valve. Carbonated water is pushed from the integral carbonator carbonated water tank by CO₂ gas head pressure and is pushed through the carbonated water manifold to the dispensing valve. Syrup and carbonated water meet simultaneous at the dispensing valve resulting in a carbonated drink being dispensed. A still (non-carbonated) drink is dispensed in the same manner as the carbonated drink except plain water is substituted for carbonated water.



NOTE



INSTALLATION

⚠ CAUTION:

Only trained and certified electrical, plumbing and refrigeration technicians should service this unit.

⚠ CAUTION:

This appliance is for indoor use only. The appliance is only to be installed in locations where its use and maintenance is restricted to trained personnel.

ALL WIRING AND PLUMBING MUST CONFORM TO NATIONAL AND LOCAL CODES.

⚠ WARNING:

It is the responsibility of the installer to ensure that the water supply to the dispensing equipment is provided with protection back flow by an air gap as defined in ANSI A 112.1.2-1979; or an approved vacuum breaker or other such method as proved effective by test and must comply with all federal, state and local codes.

Failure to comply could result in serious injury, death or damage to the equipment.

Water pipe connections and fixtures directly connected to a potable water supply shall be sized, installed and maintained according to Federal, State and Local laws.

DELIVERY INSPECTION AND UNPACKING

Each unit is completely tested thoroughly and inspected before shipment. Upon receiving the units from shipment carrier, carefully inspect the unit for visible indication of damage. If any damages exist, file a claim with the shipment carrier.

Accessories	Part No.	Quantity
Cup rest		1
Power cord		1
Drain Pipe		1
Decals	Varies with dispenser	1 set
Manual		1
Valve key		1 set

DIMENSIONS

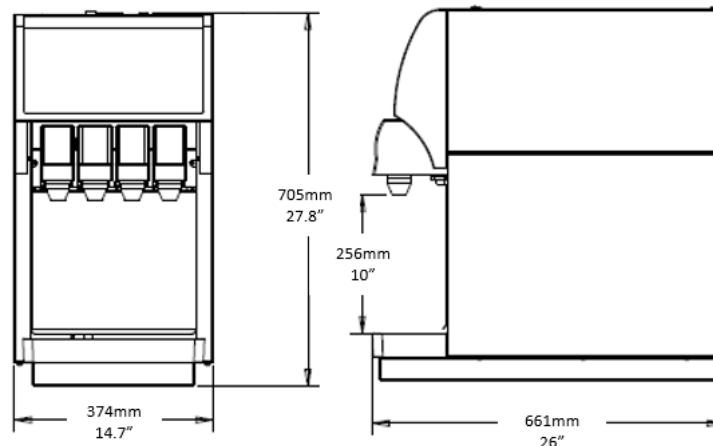

Figure 3



INSTALLATION REQUIREMENTS

Weight	Front or rear counter must be level and able to support 400 lbs.(180Kg)
Environment	Indoor installation only
Temperature	59° F to 90° F (15°C - 32.2°C)ambient temperature
Clearance	18-inches(450mm) above and 6-inches(150mm) beside
CO2	75 PSI (0.52Mpa) at unit with internal carbonator
Syrup	60 PSI (0.41Mpa)
Water	20~65PSI (0.14Mpa~0.45Mpa) NCB circuit pressure >40PSI (0.28Mpa)
Electrical	See nameplate on unit for electrical requirements

ELECTRICAL REQUIREMENTS



WARNING:

Before connecting electrical power to the unit refer to nameplate to verify power requirements. To avoid possible serious injury or death the ELCB (earth leakage circuit breaker) must be installed in electrical.



WARNING:

To avoid possible electrical shock the unit must be electrically grounded using the green grounding screw provided inside the electrical contractor box.



CAUTION:

The wiring must be properly grounded and connected through a 10-amp disconnect switch (slow-blow fuse or equivalent HVAC/R circuit breaker).

ALL WIRING MUST CONFORM TO NATIONAL AND LOCAL CODES. MAKE SURE UNIT IS PROPERLY GROUNDED.

AMBIENT TEMPERATURE REQUIREMENTS

Ambient (room) temperature **MUST NOT EXCEED 90° F (32.2° C)** Temperatures in excess of 90° F (32.2° C) will void the factory warranty and may eventually result in refrigeration system failure.

CAUTION — To avoid overheating and damaging to the unit, and voiding the warranty, there must be at least 6 - inch (0.15 m) of clearance on all sides and 18 - inch (0.45 m) on the top of the unit.

CAUTION — This unit is designed for indoor installation only (in non-harsh environments).

CAUTION — If the unit is exposed to freezing temperature, water in the unit will freeze and may damage the unit.

CAUTION — Avoid spillage into the top vents.



INSTALLATION PROCEDURE

NOTE: Optional legs will elevate the unit 4 inches above the counter (order 4 legs). If the unit is installed without legs, the gaps must be sealed with RTV.



WARNING:

The unit is heavy and extreme care should be taken when moving or lifting the unit. Do not attempt to lift the unit manually.

Failure to comply could result in serious injury, death or damage to the equipment.

Counter-top installation

NOTE: Do not insert the power cord plug until the installation is completed.

1. Place the unit on a level counter capable of supporting at least 400 pounds (180 kg).
2. Remove Merchandiser and disconnect the harness of led. Remove the two screws on the top and remove cladding.
3. Remove drip tray and splash panel. (Push up and pull out the splash panel)

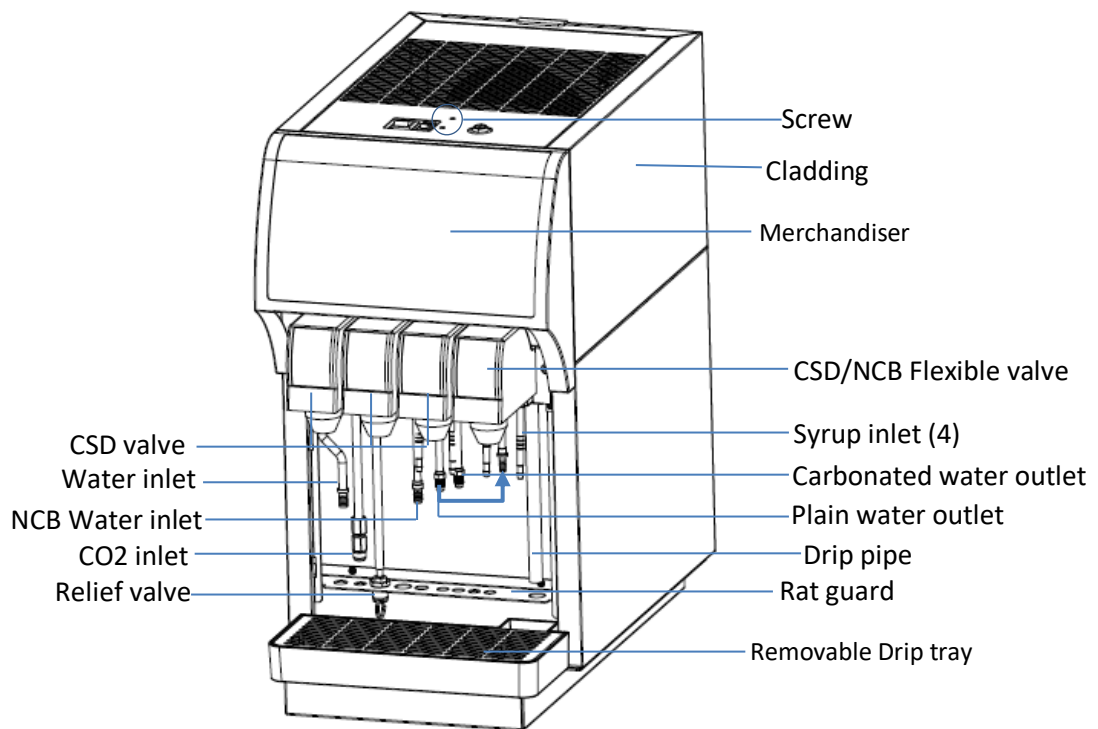

Figure 4
(Reference model)

Note: The figure 4 is for 3CSD+1Flex. model. The pipeline interfaces and valve configuration of other models are slightly different. Please refer to the label on the actual model for pipeline connection.

4. Pull water, syrup, and CO2 lines through counter or wall. To comply with NSF International requirements the unit must be sealed to the counter top and all access holes in the unit base must be sealed. Caulk/seal the unit to the counter using Dow Corning RTV 731 or equivalent approved sealant.
5. Fill the city water through the water inlet hole (Do not use distilled or deionized water). When filling water, observe the overflow pipe at all times. When the water flow out from the overflow pipe, stop filling water and cover the water inlet port with the cap.

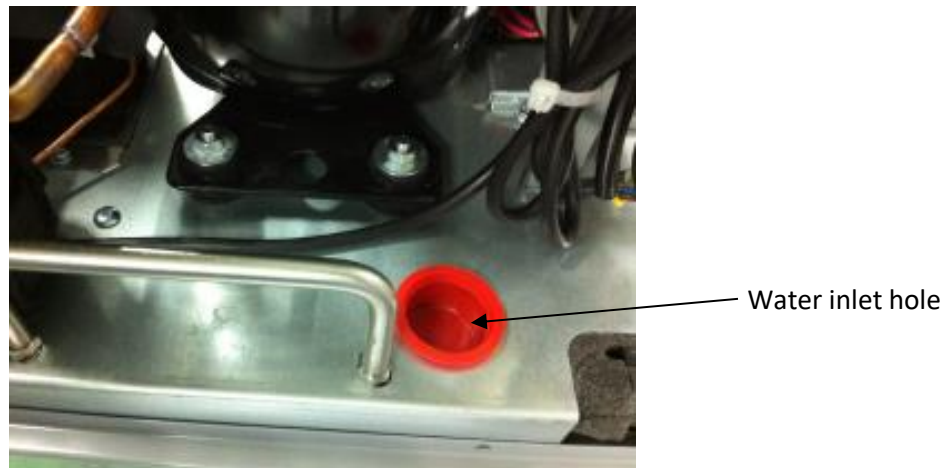

Figure 5

NOTE -- Water bath must be filled with water before the unit will run.

6. Re-install the cladding and tighten screws on the top.
7. Connect the harness and install the merchandiser.

ICE BANK CONTROL (GIBO) THEORY OF OPERATION

Once electrical power is supplied to the unit, the agitator motor will start. There will be a three minutes delay before the refrigeration compressor and the condenser fan motor start. This three minutes delay will take place each time when the electrical power is interrupted. The unit will continue to operate until ice covers all two stainless-steel pins on the ice bank control probe. The ice bank control module senses this by measuring the difference in electrical resistance between the water and the ice. When the ice on the evaporator coil becomes thick enough, it covers the two stainless-steel pins on the ice bank control probe. The control module senses there is enough ice and turns the refrigeration compressor and the condenser fan motor off. The Unit remains turned off until the ice bank control three stainless-steel pins are free of ice. Once this happens, the ice bank control module starts the refrigeration compressor and the condenser fan motor.



Connect syrup, water, and carbonated water lines

1. Connect the syrup inlet pipe, water inlet pipe and CO₂ inlet pipe according to the labels on the machine, and fasten them with clamps. Refer to figure 4 for the position of pipeline interface (different models may be slightly different, refer to the actual machine label). The pipeline can be led in from the front of the machine or from the back of the machine. No matter which kind of pipeline needs to pass through the rat guard in front of the machine before connecting. If the pipe is led in from the back of the machine, it is necessary to remove the cover plate of the pipe hole at the back of the machine and thread the pipe from the hole into the front of the machine for connection.

NOTE -- Water pipe connections and fixtures directly connected to the potable water supply must be sized, installed, and maintained in accordance with NSF Standard 18, as well as Federal, State, and Local laws and regulations.

NOTE -- It is the installer's responsibility to ensure that the water supply is equipped with protection against back flow. This protection can be an air gap as defined by ANSI/ASME A112.1.2-1979, or by an approved vacuum breaker or other approved method.

NOTE -- If water supply pressure to the unit is less than 20 psi, a water pressure booster is required. If water supply pressure to the unit is more than 65 psi, a water pressure regulator must be installed in the supply line.

NOTE -- A water shutoff valve and water filter in the water supply line are recommended.

NOTE-- Connect the CO₂ lines. Be sure the water and CO₂ are on. CO₂ should be set to 75 psig (5.25 bar) Maximum. Higher CO₂ pressure will result in lower carbonation.

2. Connect optional drip tray drain hose (if used). Be sure remove the black cap if the drain hose is used.
3. Connect the CO₂ lines. Be sure the water and CO₂ are on. CO₂ should be set at 75 psi (5.25 bar) maximum. Higher CO₂ pressure will result in LOWER carbonation. CO₂ Inlet Carbonator. Bleed the air out of the carbonator (hold with wrench) Bleed Valve by pulling up on the metal ring on the bleed valve. Bleed each valve into a bucket until water comes out for 2-3 seconds.

NOTE: The CO₂ inlet fitting is sealed inside the carbonator with an O-ring. This fitting rotates freely and must be held by a second wrench while securing the CO₂ inlet line.

4. Be sure that all syrup sources are connected and open. Bleed each valve into a bucket until syrup comes out.
5. Reinstall drip tray and position water bath overflow hose in drip tray indent.
6. Check the system for gas leaks by pressurizing the system and then turning off the cylinder valve. Wait a couple of minutes and check the cylinder gauge to see if the pressure has dropped.
7. Heck the system for water and syrup leaks.

Primary and secondary CO₂ regulator setting

1. Open CO₂ cylinder valve slightly to allow lines to slowly fill with gas. When lines are fully pressurized open the valve all the way until it back-seats itself (this prevents leaks from the valve).
2. Adjust the cylinder CO₂ regulator to 5.2 bar (75 psi) for bag-in-box applications, 2.8 bar (40 psi) for sugar base tank applications and 0.69 bar (10 psi) for diet base tank applications.
3. The Pioneer dispenser with integral cold carbonator requires CO₂ supply pressures of 5.2 bar (75 psi).
4. Bleed air from the lines with the carbonator tank relief valve.
5. Check the system for gas leaks.

Connect electrical power

NOTE: Before connecting electrical power to the dispenser, refer to nameplate to verify the power requirements.

1. Make sure that the electrical power circuit breaker is switched off or the fuse removed.
2. Plug the power cord into the power receptacle.
3. Turn electrical power ON

Check for leaks

1. Bleed air from the lines by activating dispensing valves.
2. Bleed air from carbonator (if dispenser has built-in carbonator) by opening carbonator relief valve until water escapes.
3. Check the system for CO₂ leaks by pressurizing and then turning off the cylinder valve. Wait at least two minutes and check the cylinder pressure gauge (1800 psi gauge) to see if the pressure has dropped.
4. Check the system for water and syrup leaks.

Reinstall panels

1. Turn power OFF, then reinstall front splash panel.
2. Turn power ON.
3. Check to see that the refrigeration system started after the built-in 3 minute delay.
4. Allow dispenser to form an ice bank before dispensing beverages. This will take 3-6 hours.

Adjust water-to-syrup ratio

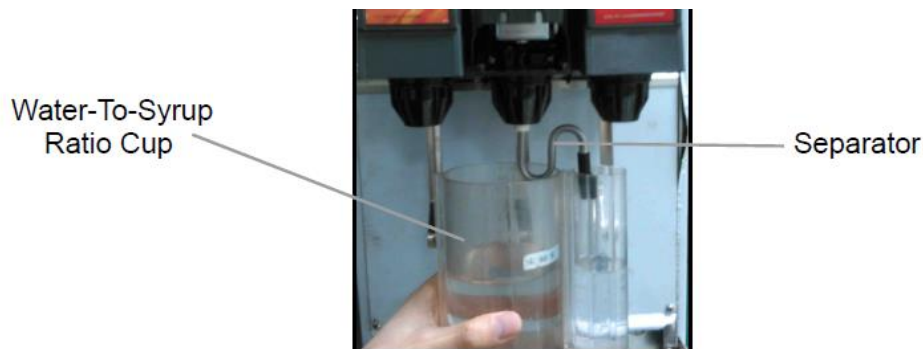

Figure 6

1. Remove valve cover and install syrup separator in place of nozzle.
2. Hold cup under valve and dispense beverage for a specific time (such as 4 seconds).
3. NOTE: Water and syrup must be cold before checking ratios.
4. Adjust carbonated water flow to the desired rate (such as 74 ml (2.5 oz) per second). Turn the flow adjuster 1/4 of a turn at a time and recheck the flow. To increase reading turn clockwise.
5. Next set syrup flow adjuster to get the desired ratio.
6. Test the valve and adjust until a consistent ratio is delivered three consecutive times.

7. Repeat procedure for other valves.



Figure 7

Adjusting flow rates

Flow rates of the water and syrup are adjusted based on the desired ratio. For example: if the desired ratio is 5:1, then the flow rate of the water is 5 times that of the syrup.

If the desired finished drink flow rate is 3.0 ounces per second, then the water flow rate is 2.5 Oz./sec. and the syrup flow rate is 0.5 Oz./sec (The water at 2.5 Oz./sec. is five times the 0.5 Oz./sec. syrup flow rate).

Flow Rates Oz./sec. Based on 5:1 Ratio

Finished Drink oz./sec.	Water oz./sec.	Syrup oz./sec.
1.5	1.25	0.25
2.0	1.67	0.33
2.5*	2.08	0.42
3.0**	2.50	0.50
3.5	2.92	0.58
4.0	3.33	0.67
4.5	3.75	0.75

NOTE: * Be applicable in NCB

** Be applicable in CSD



OPERATION

INSTRUCTIONS

Please refer to figure 1 for switch position.

1. Turn the main power switch on to power on the equipment.
2. Turn the LED light switch on to power on the merchandiser.
3. Turn the valve lock key on to open the valve.

Dispensing product

To dispense beverage press drink container against the lever or push the button on the valve cover.

Replenishing syrup supply

Tank System

1. Remove the empty syrup tank by disconnecting the syrup tube first, then the CO₂ tube.
2. Rinse the disconnects in warm water to remove any syrup residue.
3. Move a full tank into position and connect the CO₂ tube first, then the syrup tube.

Bag-In-Box System

1. Disconnect the syrup tube from the empty bag-in-box and remove the empty box.
2. Rinse the disconnects in warm water to remove any syrup residue.
3. Install a full bag-in-box and connect the syrup tube.

Adjustments

Water-to-syrup ratio adjustment

The ratio adjustment should only be done by a qualified service person.



CLEANING AND CHECKS

Daily Cleaning

1. Remove nozzle assembly and rinse with warm (not hot) water. It is recommended to soak nozzle assembly overnight in carbonated water then rinse with warm water.
2. Wash external surfaces with mild soap solution, rinse with clean water, and wipe dry. Remove the drip tray, wash with mild soap solution, rinse and dry.

NOTE: Do not use abrasive or harsh cleaners on the unit.

Daily Checks

1. Check CO2 supply.
2. Check syrup supply.

Sanitizing syrup systems

The syrup systems should be sanitized at least every 120-day and before or after storage. Prepare the sanitizer and detergent solutions as per the instructions below.

Sanitizer solution: Using a clean empty syrup tank, mix a non-scented liquid household bleach containing a 5.25% sodium hypochlorite concentration in one gallon of 70°F - 100°F (20°C - 38°C) potable water.

Detergent solution: Using a clean empty syrup tank, mix 1/2 oz. (14 g) liquid dish washing detergent per gallon of 70°F - 100°F (20°C - 38°C) potable water. Shake tank to mix.

Sanitizing Syrup Tank Systems

 **CAUTION:**
To avoid possible personal injury or property damage, DO NOT remove the syrup tank cover until CO2 pressure has been released from the tank.

1. **Disconnect Syrup:** Remove disconnects from syrup tanks and rinse in potable water.
2. **Wash System**
 - A. Connect the tank containing the detergent solution to one of the syrup circuits.
 - B. Place the waste water container under dispensing valve. Dispense for one minute to purge all syrup from the circuit.
 - C. Repeat this process for each syrup circuit.
3. **Flush System**
 - A. Connect a tank containing clean potable water to syrup circuit and pressurize to 60-80 psi. (4-5.5 bar).
 - B. Place the waste container under dispensing valve. Dispense from the valve for one minute to flush the circuit.
 - C. Repeat this process for each syrup circuit.
4. **Sanitize System**
 - A. Connect the tank containing the sanitizer solution to syrup circuit and pressurize to 60-80 psi. (4-5.5 bar).
 - B. Place the waste container under dispensing valve. Dispense from the valve for till the sanitizing solution is dispensed for 30 seconds.
 - C. Allow the sanitizing solution to remain in circuits for at least 10 minutes but no more than 15 minutes.
 - D. Dispense from the valve until the whole sanitization solution is used up.



E. Repeat this process for each syrup circuit.

5. Flush System

IMPORTANT: The flushing solution must not exceed 200 PPM chlorine.

- A. Connect a tank containing clean potable water to the syrup circuit and pressurize to 60-80 psi. (4-5.5 bar).
- B. Place waste container under dispensing valve. Dispense from the valve for one minute to flush the circuit.
- C. Repeat this process for each syrup circuit.



CAUTION:

Flush the system thoroughly, residual sanitizing solution left in the system could create a health hazard.

Sanitizing Bag-In-Box syrup system

To sanitize a Bag-in-Box system follow the same procedure as the tank system described above, with following exceptions:

1. Use a clean container (like a 5 gallon (20 l) plastic bucket) to mix solutions and hold flushing water.
2. Cut bag valves from empty BIB containers. Clean them and connect them to the ends of the syrup lines.
3. Place syrup lines with bag valves into the container of solution.

Condenser Cleaning

Accumulation of dust and grease on the refrigeration condenser can cause overheating. The condenser should be cleaned as often as necessary to avoid overheating using the following procedure.

1. Remove the cladding and merchandiser.
2. Vacuum or use a soft brush to clean the condenser. Low pressure compressed air can be used if conditions permit.
3. Clean around top of refrigeration assembly.
4. Reinstall the cladding and merchandiser.

Clean Air Filter



CAUTION:

Accumulation of dust and grease on the air filter can cause condenser overheating. The filter should be cleaned as often as necessary to avoid overheating using the following procedure.

1. Disconnect electrical power to the dispenser.
2. Pull out the air filter from top panel.
3. Vacuum and use soft brush to clean the filter.
4. Place the cleaned filter back in position.

Sanitizing by Diversol CX

1. Mix Diversol CX with 20°C water (64g/10L) to make sanitation solution.
2. Sanitizing syrup and water system by below steps:
 - 1) Use water to clean the system continuously by 10 minutes.

Push the valve lever and dispense the drink 0.4 Liter, then stop 10 seconds .Repeat this step and complete after 10 minutes.

- 2) Sanitizing by sanitation solution, and keep the solution in all position of system for 60 minutes.
- 3) Use sanitation solution to clean the system continuously by 10 minutes.[Same as 1)]



4) Sanitizing by sanitation solution, and keep the solution in all position of system for 60 minutes.

3. Use water to clean syrup and water system continuously by below steps:

1) Step1. Clean continuous by 3 minutes and pause for 5 minutes.

Push the valve lever and dispense the drink 0.4 Liter, then stop 10 seconds .Repeat this step and complete after 3 minutes.

2) Step2. Repeat the first step 10 times.

4. Drop first 3 cups of drinking.



SERVICE



CAUTION:

Only trained and certified electrical, plumbing and refrigeration technicians should service this unit.

ALL WIRING AND PLUMBING MUST CONFORM TO NATIONAL AND LOCAL CODES.

PREVENTATIVE MAINTENANCE

Preventative Maintenance Summary

Preventative Maintenance Summary	
Procedure	Frequency
Sanitize Unit	3 months
Check Ratio	6 months
Clean Condenser	6 months and as needed
Carbonator Double Liquid Check Valve	annually
Check for Leaks	annually
Clean BIB Connectors	annually
Clean air Filter	As needed

Sanitizing

The syrup systems should be sanitized every 3 months using non-scented liquid household bleach containing a 5.25% sodium hypochlorite concentration. See the Operation section of this manual for sanitizing procedure.

Double Liquid Check Valve Inspection & Cleaning

The carbonator double-liquid check valve must be inspected after any disruptions to the water supply system (plumbing work, earth quakes, etc.) It should also be inspected at least once a year under normal conditions. If particles lodge in the check valve CO₂ gas could back flow into the water system and create a health hazard.

1. Disconnect electrical power to the dispenser.
2. Shut off CO₂, syrup, and water supplies to the dispenser.
3. Check seat and O-rings. Replace if necessary.

Check for Leaks

Periodically check syrup, water, CO₂, and drain for leaks.

Check Ratio

Should be done whenever flavors are changed or any service is performed.

Clean Condenser

Accumulation of dust and grease on the refrigeration condenser can cause overheating. The condenser should be cleaned as often as necessary to avoid overheating using the following procedure.

1. Remove the cladding and merchandiser.
2. Vacuum or use a soft brush to clean the condenser. Low pressure compressed air can be used if conditions permit.
3. Clean around top of refrigeration assembly.
4. Reinstall the cladding and merchandiser.
5. Reinstall side panels and top panel and close the merchandiser.



Clean BIB Connectors

See the Operation section of this manual.

Clean Air Filter

Accumulation of dust and grease on the air filter can cause overheating. The filter should be cleaned as often as necessary to avoid overheating using the following procedure.

1. Disconnect electrical power to the dispenser.
2. Remove the condenser filter from top accessible slot.
3. Take out the filter and clean it with water.

ADJUSTMENTS

CO2 Connection

1. Unscrew protector cap (with chain attached) from CO₂ cylinder valve. Open CO₂ cylinder valve slightly counter clockwise to blow any dirt or dust from outlet fitting before installing primary CO₂ regulator, then close valve.
2. Remove shipping plug from primary CO₂ regulator assembly coupling nut and make sure gasket is in place inside nut. Install regulator assembly on CO₂ cylinder so gages can be easily read, then tighten coupling.
3. Connect soft drink tanks CO₂ lines to primary CO₂ regulator manifold assembly.
4. Install gas quick disconnects on ends of soft drink tank CO₂ lines.



CAUTION:

To avoid personal injury and property damage. Always secure CO₂ cylinder in upright position with a safety chain to prevent it from falling over.



WARNING:

CO₂ displaces oxygen. Persons exposed to high concentrations of CO₂ will experience tremors, followed by loss of consciousness and death. It is very important to prevent CO₂ leaks, especially in small unventilated areas. If a CO₂ leak occurs ventilate the area before fixing the leak.

Primary and Secondary CO2 Regulator Settings

1. Open CO₂ cylinder valve slightly to allow lines to slowly fill with gas. When lines are fully pressurized open the valve all the way until it back-seats itself (this prevents leaks from the valve).
2. Adjust the cylinder CO₂ regulator to 70 psi (4.8 bar) for bag-in-box applications. 40 psi (2.8 bar) for sugar base tank applications and 10 psi (0.7 bar) for diet base tank applications.
3. The Pioneer dispenser with integral cold carbonator requires CO₂ supply pressure of 75 psi (5.2 bar).
4. Bleed air from the lines with the relief valves.
5. Check the system for gas leaks.



Notes



COMPONENT SERVICE

⚠ CAUTION:

Also make sure that the power supply is disconnected before any maintenance operations. Failure to comply will result in serious injury, death or damage to the equipment.

⚠ CAUTION:

Before maintenance, the water supply system must be closed and the pressure in the pipeline must be released in advance. Failure to comply will result in serious injury, death or equipment damage.

CARBONATOR PUMP REPLACEMENT

1. Disconnect power to the unit.
2. Shut off water and CO₂ at their sources.
3. Remove top panel and side cladding.
4. Depressurize carbonator by removing the solenoid dust cover from any dispensing valve and press valve lever to release the pressure.
5. Disconnect water in and out lines.
6. Loosen the V-band clamp and remove pump.
7. Install new pump.

PUMP MOTOR REPLACEMENT

1. Disconnect power to the unit.
2. Remove top panel and side cladding.
3. Unplug motor harness.
4. Loosen the V - band clamp and remove pump.
5. Remove bolts and remove the motor.
6. Install new motor by reversing this procedure.

AGITATOR MOTOR REPLACEMENT

1. Disconnect power to the unit.
2. Remove top panel and side cladding.
3. Unplug motor harness.
4. Remove mounting screw.
5. Install new motor by reversing this procedure.

CONDENSER FAN MOTOR REPLACEMENT

1. Disconnect power to the unit.
2. Remove the Merchandiser and cladding of the machine.
3. Unplug the motor harness, remove 2 screws from the motor bracket, and remove the motor fan assembly.
4. Remove the three screws fixed between the motor and the bracket, and remove the blades.
5. Install the new mixing motor on the bracket, and install the machine according to the opposite steps (pay attention to the direction of the blades).



NOTES



TROUBLE SHOOTING

WARNING:
Only an authorized service person should service internal components or electrical components.

CAUTION:
If repairs are to be made to one of the syrup circuits, disconnect applicable syrup tank and bleed pressure from the system before proceeding.

WARNING:
If repairs will be made to the CO₂ or carbonated water systems, disconnect electrical power to the carbonator, shut off CO₂ and water supplies, and then bleed systems before proceeding.

WARNING:
To avoid personal injury disconnect electrical power to the unit before attempting any electrical repairs or working on the internal parts of the unit.

Troubleshooting Post-mix System

Trouble	Probable Cause	Remedy
Adjustment of dispensing valve syrup flow regulator does not increase to desired water-to syrup ratio.	<ol style="list-style-type: none"> 1. No syrup supply. 2. Syrup supply container not securely connected into system. 3. Tanks System-Syrup tanks secondary CO₂ regulator out of adjustment. Bag-in-Box System- Primary CO₂ regulator out of adjustment. 4. Inoperative dispensing valve syrup flow control. 5. Tapered washer inside tube swivel nut connection distorted from being over tightened restricting syrup flow. 6. Pressure to BIB/Syrup tank is too low. 	<ol style="list-style-type: none"> 1. Replenish syrup supply. 2. Securely connect syrup supply container into syrup system. 3. Adjust syrup tanks secondary CO₂ regulator as instructed. Adjust primary CO₂ regulator as instructed. 4. Repair dispensing valve syrup flow control. 5. Replace tapered gasket. Make sure it seats properly. 6. Adjust the pressure as per the specifications.
Adjustment of dispensing valve syrup flow regulator does not decrease to desired water-to-syrup ratio.	<ol style="list-style-type: none"> 1. Dirty or inoperative dispensing valve syrup flow control. 	<ol style="list-style-type: none"> 1. Disassemble and clean dispensing valve syrup flow control/
Dispensed product carbonation too low.	<ol style="list-style-type: none"> 1. Primary CO₂ regulator out of adjustment for existing water conditions or temperature. 2. Air in carbonator water tank. 3. Water, oil, or dirt, in CO₂ supply. 4. CO₂ supply depleted. 	<ol style="list-style-type: none"> 1. Adjust primary CO₂ regulator. As instructed. 2. Vent air out of carbonator water tank through relief valve. 3. Remove contaminated CO₂. Clean CO₂ system (lines, regulator, etc.) using a mild detergent. Install a clean CO₂ supply. 4. Replenish CO₂ supply.
Dispensed product comes out of dispensing valve clear but foams in cup or glass.		<ol style="list-style-type: none"> 1. Use clean cups or glasses. 2. Do not use ice directly from freezer. Allow ice to become "wet" before using. (refer to following NOTE).

NOTE: Crushed ice also causes dispensing problems. When finished drink hits sharp edges of ice, carbonation is released from dispensed drink.



<p>Dispensed product produces foam as it leaves dispensing valve.</p>	<ol style="list-style-type: none"> 1. Recovery rate of refrigeration of system exceeded, ice bank depleted. 2. Primary CO₂ regulator pressure too high for existing water conditions or temperature. 3. Tanks System-Syrup over-carbonated with CO₂ as indicated by bubbles in inlet syrup lines leading to unit. 4. Dispensing valve restricted or dirty. 5. Tapered gasket inside carbonated water line swivel nut connector distorted restricting carbonated water flow. 6. Dirty water supply. 7. Finished drink above 4.4° C (40° F). 	<ol style="list-style-type: none"> 1. Allow ice bank to recover. 2. Reduce primary CO₂ regulator pressure settings. 3. Remove syrup tanks quick disconnects. Relieve tank CO₂ pressure as many times as necessary to remove over-carbonation. 4. Sanitize syrup system as instructed in Service and Maintenance Manual. 5. Replace tapered gasket. Make sure it is properly seated. 6. Check water filter. Replace cartridge. 7. Check refrigeration system.
<p>No product dispensed.</p>	<ol style="list-style-type: none"> 1. No electrical power to dispenser. 2. Disconnected dispensing valves power cord. 3. Disconnected or broken wiring to dispensing valve. 4. Inoperative transformer or dispensing valve solenoids. 	<ol style="list-style-type: none"> 1. Plug in dispenser power cord or check for blown power fuse or tripped circuit breaker. 2. Connect dispensing valves power cord. 3. Connect or replace wiring. 4. Replace inoperative part.
<p>Only carbonated water dispensed.</p>	<ol style="list-style-type: none"> 1. Syrup supply container not securely connected into syrup system. 2. No syrup supply. 3. Bag-in-Box System – Inoperative syrup pump. Tanks System – Syrup tanks CO₂ regulator not properly adjusted. 4. Inoperative dispensing valve. 5. Dispensing valve syrup flow control not properly adjusted. 	<ol style="list-style-type: none"> 1. Securely connect syrup supply container into syrup system. 2. Replenish syrup supply. 3. Replace inoperative syrup pump. Adjust syrup tanks CO₂ regulator as instructed. 4. Repair dispensing valve. 5. Adjust dispensing valve syrup flow control (Water-to-Syrup ratio) as instructed.
<p>Compressor will not stop after sufficient ice bank is produced.</p>	<ol style="list-style-type: none"> 1. Ice bank probe location incorrect. 2. Ice temperature sensor inoperative. 3. Control board inoperative. 	<ol style="list-style-type: none"> 1. Place probe in proper location. 2. Replace ice temperature sensor. 3. Place power switch in ON position.
<p>Compressor operates continuously but does not form sufficient ice bank.</p>	<ol style="list-style-type: none"> 1. Cooling capacity is exceeded by overdrawing. 2. Unit located in excessively hot area or air circulation through condenser coil is restricted. 	<ol style="list-style-type: none"> 1. Reduce amount of drinks drawn per given time. 2. Relocate unit or check and if necessary, clean condenser coil as instructed.
<p>Carbonator pump not operating</p>	<ol style="list-style-type: none"> 1. 3 minutes run limit exceeded. 2. Water supply to carbonator disrupted. 3. Carbonated water tank water level probe electrical wiring disconnected. 4. Inoperative carbonated water tank water level probe. 5. Inoperative carbonator pump or motor. 6. Inoperative control board. 	<ol style="list-style-type: none"> 1. Turn power OFF for 15 second. 2. Correct water supply problem. 3. Connect electrical wiring to water level probe (see note). 4. Replace probe (see note). 5. Replace pump or motor. 6. Replace control board.



<p>Agitator motor not operating.</p>	<ol style="list-style-type: none"> 1. No power source (blown fuse or tripped circuit breaker). 2. Agitator motor propeller obstructed. 3. Low Voltage. 4. Loose, disconnected, or broken wiring. 5. Inoperative agitator motor. 	<ol style="list-style-type: none"> 1. Replace fuse or reset circuit breaker. (NOTE: Fuse or circuit breaker are not part of unit). 2. Remove obstruction. 3. Voltage must be 90- 135VAC (110-120 volt unit) or 180-260(230 VAC unit) at compressor terminals when compressor is trying to start. 4. Tighten connections or replace broken wiring. 5. Replace agitator motor.
<p>Refrigeration compressor does not operate.</p>	<ol style="list-style-type: none"> 1. Ice bank sufficient. 2. No water in water tank. 3. Control board power switch on top of unit in "OFF" position. 4. Unit power cord un-plugged, or drop-in refrigeration assembly power cord unplugged. 5. Ice sensor electrically disconnected. 6. No power source (blown fuse or tripped circuit breaker). 7. Low/high voltage. 8. Loose, disconnected, or broken wiring. 9. Overload protector cut out; overheated compressor. Condenser fan motor not operating as required. 10. Inoperative overload protector or start relay. 11. Inoperative ice bank probe. 12. Inoperative control board. 	<ol style="list-style-type: none"> 1. No refrigeration called for. 2. Fill water tank with water as instructed. 3. Place control board power switch in "ON" position (will be a built-in 3-minute time delay before refrigeration compressor starts). 4. Plug in power cord. 5. Electrically connect or replace inoperable sensor. 6. Replace fuse or reset circuit breaker. (Note: Fuse or circuit breaker are not part of unit). 7. Voltage must be 180- 255 Volts or 90 -130Volts. 8. Tighten connections or replace broken wiring. 9. Compressor will cool enough to restart, Do not overdraw cooling capacity of unit. Refer to "Condenser Fan Motor Not Operating" in this section. 10. Replace inoperative part. 11. Replace ice bank probe. 12. Replace control board.



REFERENCE MATERIAL

WIRING DIAGRAM

WIRING DIAGRAM 电路图

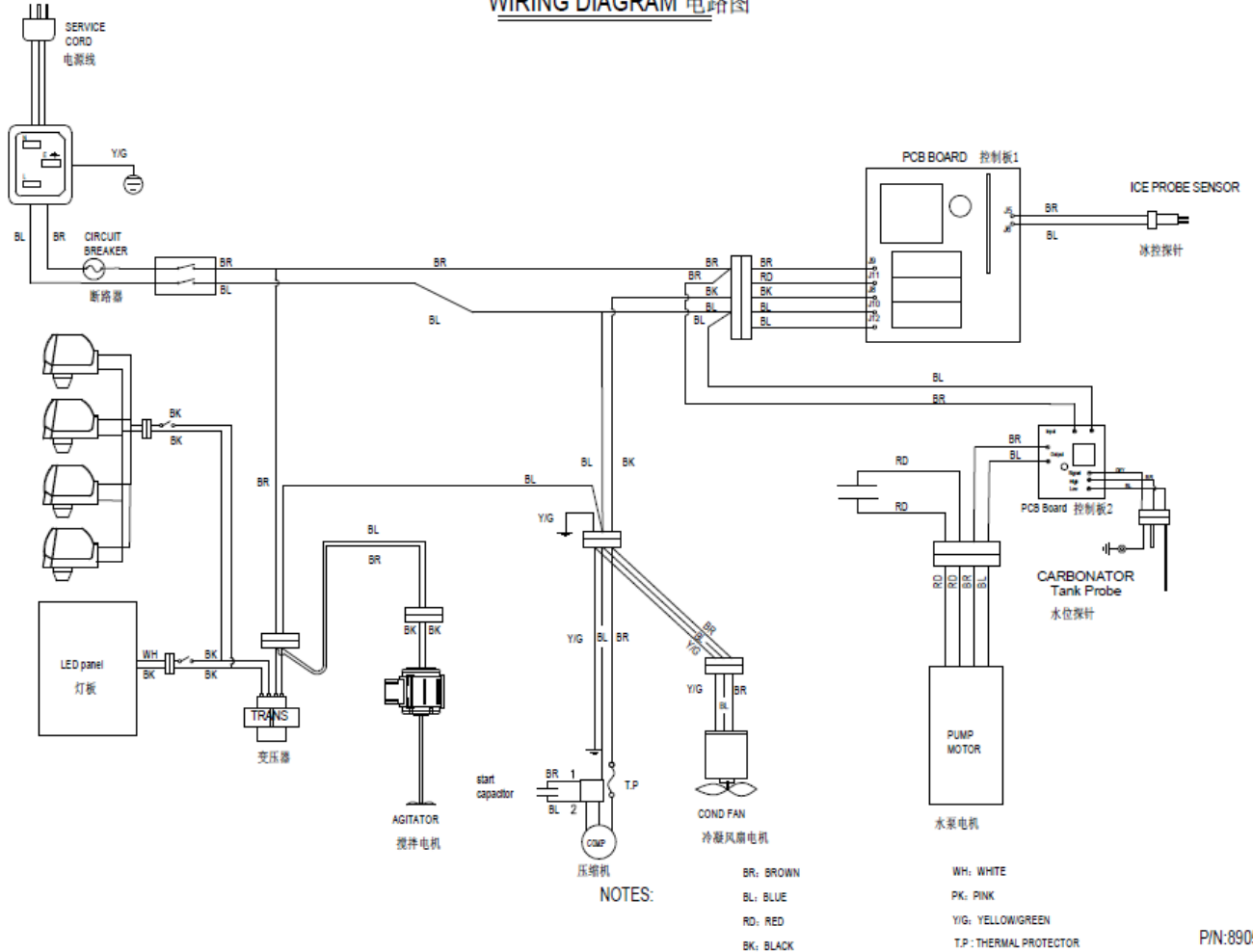

P/N:890569201



PLUMBING DIAGRAM_3CSD+1Flex. Model

PLUMBING DIAGRAM 管路图

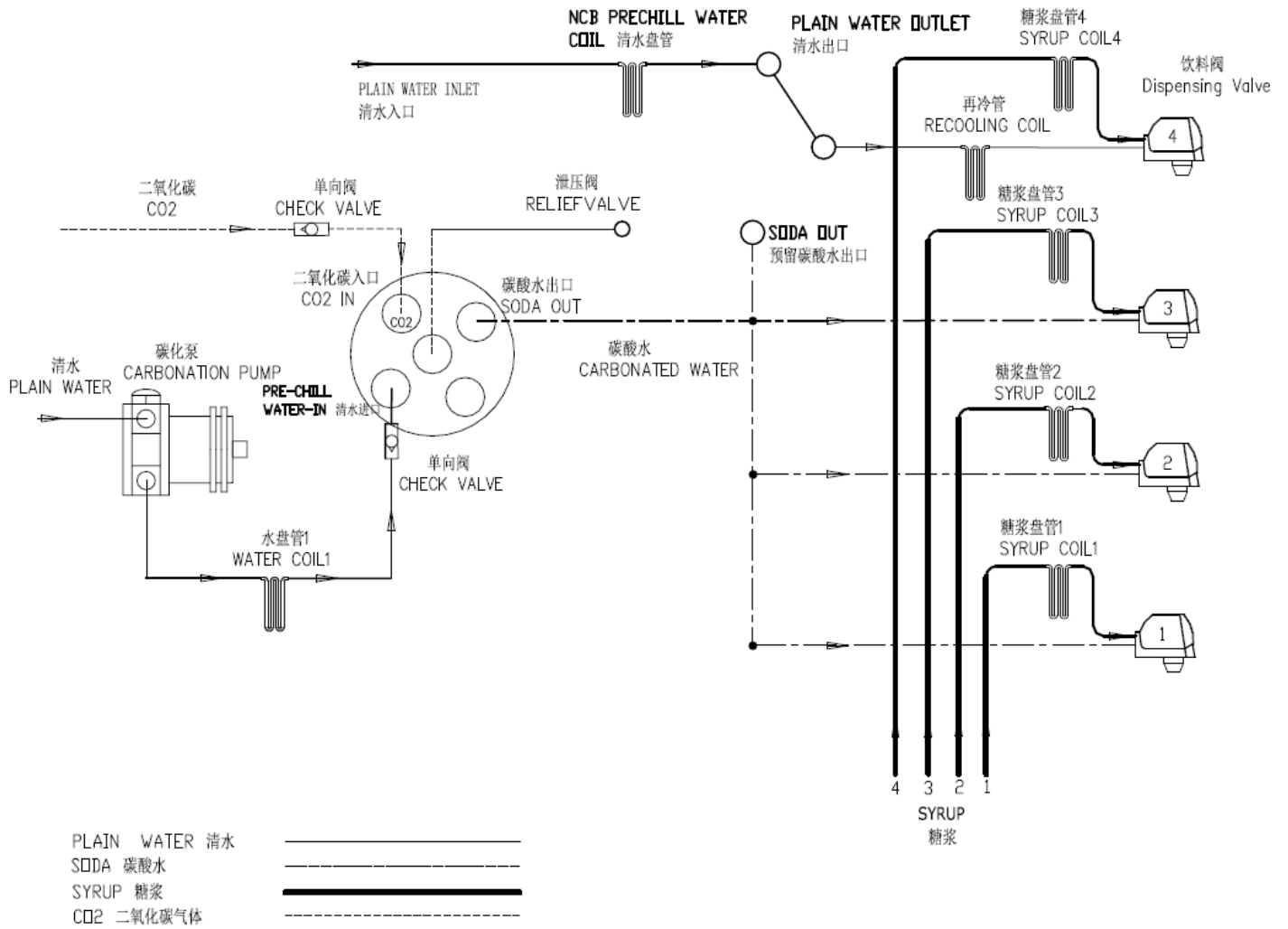

P/N890569215

Cornelius Inc.
www.cornelius.com