

## Titan HC



### FEATURES

#### Merchandising

Large and interchangeable LED illuminated graphic for maximum impact. LED lit flavour cards for brand visibility.

#### Ease of service

Independent refrigeration deck for easy service and maintenance. Structure design allows quick access to key components.

#### Excellent performance

Optimized ice bank and product delivery system ensuring in-spec drink dispense even in Very High Ambient environment.

#### Life cost savings

Optimum air flow control, increased insulation, efficient heat exchange, external removable condenser filter, LED illumination, R290 green refrigerant all contribute to energy efficiency and prolonged component lifetime.

#### Beverage flexibility

Quick hand operated changeover manifold without need for tools and plumbing.

#### Reliability & Sustainability

R290 green refrigerant and global agency (GB, CE, ETL Sanitation)

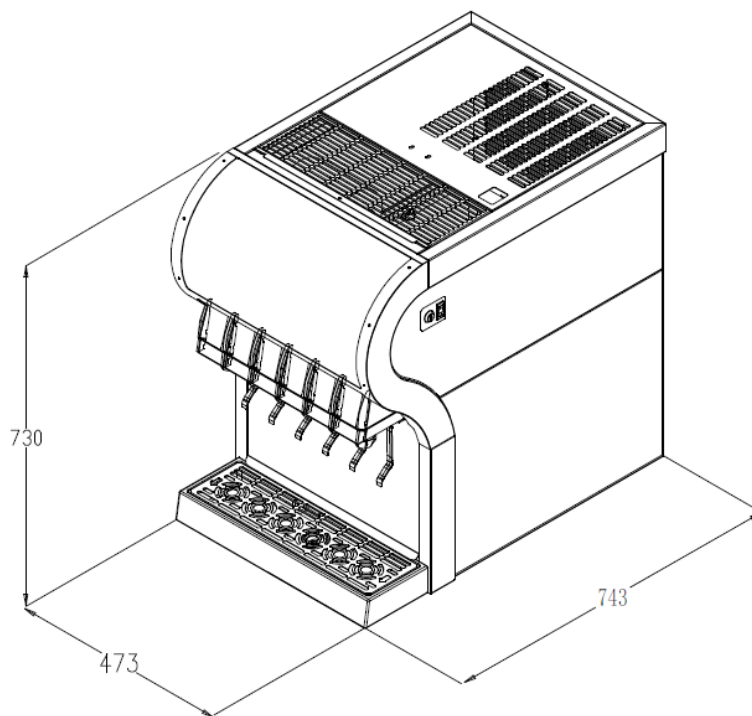

## TECHNICAL SPECIFICATIONS

<b>TYPE OF VALVES</b>	SFV	<b>ELECTRICAL REQUIREMENTS</b>	230V/50Hz
<b>NUMBER OF VALVES</b>	6		
<b>CUP CLEARANCE</b>	250mm		
		<b>Housing Material</b>	Painting Steel
<b>CONTINUOUS DRAW CAPACITY at 12oz, 2 drinks/m</b>			
@105°F (40.6°C) 75%RH	63cups	<b>Coil Material</b>	SS 304
@90°F (32.2°C) 65%RH	126cups		
@75°F (23.9°C) 45%RH	277cups		
<b>COMPRESSOR SIZE</b>	1/3+HP	<b>DIMENSIONS (mm)</b>	730(H)*473(W)*743(D)
<b>REFRIGERANT</b>	R290		
<b>WATER BATH SIZE</b>	48L	<b>PRODUCT WEIGHT</b>	80KG
<b>ICE BANK</b>	12KG		